

**DEPARTMENT OF CONSUMER AFFAIRS**  
*Bureau of Security and Investigative Services*



**FIREARMS TRAINING MANUAL**

**OCTOBER 2012**



**STATE OF CALIFORNIA  
BUREAU OF SECURITY AND INVESTIGATIVE SERVICES  
FIREARMS TRAINING MANUAL**

**TABLE OF CONTENTS**

	<u>Page</u>
TABLE OF CONTENTS.....	2
FIREARMS TRAINING OUTLINE--Recommended Instruction Sequence.....	8
<b>I. REGISTRATION .....</b>	<b>14</b>
A. Administration .....	14
1. Check individual identification / proof of permanent residence.....	14
2. Check registration / license status.....	14
3. Have state forms filled out (Complete application).....	15
4. Have training school forms filled out (Complete training roster) .....	15
5. Course admission and discussion.....	15
B. Laws and regulations for issuing a firearms qualification card.....	15
<b>Attachment I - Acceptable evidence of U.S. Citizenship or Permanent Residence.....</b>	<b>21-22</b>
<b>II. MORAL AND LEGAL ASPECTS .....</b>	<b>23</b>
A. Laws regarding possession and carrying of firearms .....	23
1. Penal Code sections .....	24
2. Government Code sections .....	37
3. Bureau Statutes and Regulations .....	43
4. Instructor Sample.....	45
B. Laws and standards regarding use of deadly force .....	45

1.	Penal Code sections .....	45
2.	Government Code sections .....	46
3.	Bureau Statutes and Regulations .....	47
4.	Instructor Sample .....	47
C.	Avoidance of deadly force - The de-escalation of force.....	47
1.	Avoid, observe and report.....	49
2.	Cover and Concealment.....	49
3.	Escalation of Force .....	50
4.	Self Control.....	50
5.	Visual Presence.....	50
6.	Verbal Communication.....	50
7.	Physical Control Levels .....	51
8.	Principles of De-escalation .....	53
9.	Case Studies .....	53
D.	Shooting incidents.....	61
1.	Criminal liability.....	61
2.	Civil liability .....	61
E.	Effects of firearm use.....	62
<b>III.</b>	<b>FIREARM NOMENCLATURE AND MAINTENANCE .....</b>	<b>62</b>
A.	The Revolver and semi automatic, ammunition, parts and nomenclature.....	62
1.	Picture of revolver and semi-automatic with parts identified.....	62
a.	Illustration “A” Revolver with parts identified.....	64
b.	Illustration “B” Semi-automatic with parts identified .....	65

2.	Revolver and semi-automatic, parts and description .....	62
	I. Revolver .....	62
	II. Semi-automatic.....	63
3.	Picture of ammunition with parts identified .....	63
	a. Illustration “C” Ammunition with parts identified .....	66
4.	Ammunition parts and description.....	63
<b>B.</b>	<b>Firearms Safety, General .....</b>	<b>67</b>
1.	General safety rules .....	67
2.	Specific safety rules .....	67
3.	Safety at home and off duty .....	68
4.	Transporting the weapon to the range.....	68
5.	Carrying the weapon on duty.....	68
6.	Suggested eye and ear protective equipment.....	69
7.	Inspection, cleaning and maintenance .....	69
	a. General Information.....	69
	b. Inspection.....	69
	1. Revolver.....	69
	2. Semi-Automatic .....	70
	c. Cleaning .....	71
	d. Cleaning kit.....	71
	e. To clean the weapon .....	72
	f. Check list.....	72
<b>IV.</b>	<b>WEAPON HANDLING AND SHOOTING FUNDAMENTALS .....</b>	<b>73</b>

A.	Weapon fundamentals, general differences between handguns .....	73
1.	Revolvers .....	73
2.	Semi-Automatics.....	73
B.	Loading and Unloading .....	73
1.	Proper loading procedures .....	73
2.	Proper loading procedures (right handed) .....	73
a.	Revolver .....	73
b.	Semi-automatic .....	74
3.	Proper unloading procedures (right handed) .....	74
a.	Revolver .....	74
b.	Semi automatic.....	75
4.	Proper loading procedures (left handed).....	75
5.	Proper Unloading procedures (left handed).....	75
6.	Loading devices .....	76
C.	Proper Positions .....	76
1.	Point Shoulder Position .....	76
2.	Standing, Barricade or Supported Position.....	76
3.	Kneeling Position.....	77
4.	Sitting Position.....	77
5.	Prone Position .....	77
6.	Cover and Concealment (Instructor Discussion).....	77
7.	Bouncing Bullets (Instructor Discussion).....	77
D.	Grip .....	78

1.	Two-Handed Grip .....	78
2.	One-Handed Grip.....	78
E.	The Draw .....	78
1.	General Information.....	78
2.	The holster and the draw.....	78
	ILLUSTRATION D (The Draw).....	80
F.	Shooting Fundamentals.....	81
1.	Sight Alignment.....	81
2.	Trigger Squeeze (control).....	81
a.	Single action.....	82
b.	Double action.....	82
c.	Count your shots .....	82
d.	Anticipation .....	82
e.	Dry firing.....	82
3.	Establishing the Dominant Eye.....	83
	Correct sight alignment (Illustration E).....	84
4.	Breath control .....	83
<b>V.</b>	<b>EXAMINATION.....</b>	<b>85</b>
<b>VI.</b>	<b>RANGE PREPARATION.....</b>	<b>85</b>
A.	Range Location .....	85
B.	Equipment needed .....	85
C.	Course of Fire (explanation).....	85
D.	Targets, scoring explanation (NRA B-27A or NRA B-21) .....	86

E.	Range commands .....	86
F.	Use of deadly force .....	86
<b>VII.</b>	<b>RANGE TRAINING.....</b>	<b>86</b>
A.	Instructions .....	86
B.	Drawing and Holstering Practice.....	88
C.	Dry Firing .....	88
D.	Loading and Reloading Procedures .....	88
<b>VIII.</b>	<b>RANGE QUALIFICATION (Course of fire).....</b>	<b>88</b>
<b>IX.</b>	<b>REQUALIFICATION.....</b>	<b>90</b>
<b>X.</b>	<b>EMERGENCY PROCEDURES.....</b>	<b>90</b>
<b>XI.</b>	<b>PEACE OFFICER QUESTIONS AND ANSWERS .....</b>	<b>91</b>

**STATE OF CALIFORNIA  
BUREAU OF SECURITY AND INVESTIGATIVE SERVICES  
FIREARMS TRAINING MANUAL**

**CALIFORNIA CODE OF REGULATIONS, TITLE 16, CHAPTER 7, SECTION 635**

**FIREARMS TRAINING OUTLINE--Recommended Instruction Sequence**

Subject and Objective

Length of Time

I. Registration (Classroom)

A. Administration. 1/2 hour

**Objective:** To enroll the individual in a course.

1. Check the individual's identification / proof of permanent residence
2. Check the individual's registration / license status.
3. Have state forms filled out (Complete application)
4. Have training school forms filled out (Complete training roster)
3. Course admission and discussion

B. Laws and regulations for issuing a firearms qualification card. 1/2 hour

**Objective:** To familiarize and instruct the individual on the laws, regulations, requirements, and the administrative process for issuing a firearms qualification card and annual renewals.

II. Moral and Legal Aspects (Classroom)

A. Laws regarding possession and carrying of firearms 1/2 hour

**Objective:** To familiarize and instruct the individual on the applicable California laws relating to the possession and carrying of firearms while working as an armed security guard.

1. Penal Code sections
2. Government Code sections
3. Bureau statutes and regulations
4. Instructor sample

B. Laws and standards regarding use of deadly force 2 hours

**Objective:** To familiarize and instruct the individual on the meaning of deadly force, the standards for using deadly force, the applicable laws relating to the use of deadly force and the consequences of using deadly force improperly or of violating the standards and requirements for use of a weapon.



1. Penal Code sections
  2. Government Code sections
  3. Bureau statutes and regulations
  4. Instructor sample
- C. Avoidance of deadly force - The de-escalation of force. 2 hours
- Objective:** To familiarize and instruct the individual on the role of the armed security guard, the role that deadly force may play and when and how to de-escalate the use of deadly force.
- D. Shooting incidents. 1 hour
- Objective:** To familiarize and instruct the individual on what is likely to happen in a shooting incident and how an armed security guard should act to minimize the use of deadly force.
- E. Effects of firearms use. 1/2 hour
- Objective:** To familiarize and instruct the individual on how and why bullets travel and what implications this has on the use of deadly force.
- III. Firearms Nomenclature and Maintenance (Classroom)
- A. The revolver and semi-automatic, ammunition, parts and nomenclature. 1 hour
- Objective:** To familiarize and instruct the individual on the principles and operation of weapons, the differences between weapons and how to care for a weapon.
1. Picture of revolver and semi-automatic with parts identified.
  2. Revolver and semi-automatic, parts and description.
  3. Picture of ammunition with parts identified.
  4. Ammunition parts and description.
- B. Firearms safety, general. 1 hour

**Objective:** To familiarize and instruct the individual on how to safely fire, wear and store the weapon, while on the firing range, or while on duty or off duty.

1. General safety rules.
2. Specific safety rules.
3. Safety at home and off duty.
4. Transporting the weapon to the range.
5. Carrying the weapon on duty.
6. Suggested eye and ear protective equipment.
7. Inspection, cleaning, and maintenance
  - a. General information
  - b. Inspection
  - c. Cleaning
  - d. Cleaning kit
  - e. To clean the weapon
  - f. Check list

IV. Weapon Handling and Shooting Fundamentals.

1 hour

**Objective:** To familiarize and instruct the individual on the fundamentals of marksmanship and the handling of weapons.

A. Weapon fundamentals, general differences between handguns

B. Loading/ Unloading

1. Proper loading procedures
2. Proper loading procedures (right handed)
3. Proper unloading procedures (right handed)
4. Proper loading procedures (left handed)

5. Proper unloading procedures (left handed)
  6. Loading devices
- C. Proper positions
1. Point shoulder position
  2. Standing, barricade or supported position
  3. Kneeling position
  4. Sitting position
  5. Prone position
  6. Cover and Concealment
  7. Bouncing bullets
- D. The Grip
1. Two-handed grip
  2. One-handed grip
- E. The Draw
1. General Information
  2. The holster and the draw
- F. Shooting Fundamentals
1. Sight Alignment
  2. Trigger Squeeze (control)
    - a. Single action
    - b. Double action
    - c. Count your shots
    - d. Anticipation

e. Dry firing

3. Establishing the dominant eye

4. Breath control

V. Examination 1 hour

VI. Range Preparation (classroom). 1 hour

**Objective:** Individual will review range safety and the fundamentals of marksmanship and deployment of weapons. In addition, the individual will review requirements for the use of deadly force.

A. Range Location.

B. Equipment needed.

C. Course of Fire (explanation).

D. Targets, scoring (explanation) (NRA B-27A OR NRA B-21).

E. Range commands (Instructor explanation).

F. Use of deadly force.

VII. Range Training. As needed

**Objective:** To instruct the individual in the safe and accurate use of a firearm until such time as the individual demonstrates to the instructor that he or she can safely draw and fire the weapon and has a high likelihood of passing the qualification course.

A. Instructions

B. Drawing and holstering practice

C. Dry firing

D. Loading and reloading procedures

VIII. Range Qualification.

A. A course of fire

## B. Scoring

# STATE OF CALIFORNIA BUREAU OF SECURITY AND INVESTIGATIVE SERVICES FIREARM TRAINING MANUAL

## I. REGISTRATION

### A. Administration (Course Admission and Discussion)

Course admission is at the discretion of the instructor. If the instructor believes that an individual may be a hazard to self or others, the instructor may exclude that individual from the course. Firearms, ammunition, and/or equipment deemed unacceptable by the instructor will not be allowed in the classroom or on the range.

#### Instruction Discussion

The instructor is to inform students that unless they provide proof of citizenship, or legal residence and authorization to work, they are not allowed to participate in the course. (Business and Professions Code Section 7585.8(a)) (See Attachment I on page 22 & 23).

### **1. Check individual identification / proof of permanent residence**

The instructor is responsible for verifying the identification of individuals taking the Firearm Training Course by checking the driver's license or other photo and/or signature identification.

The instructor is also responsible for verifying the citizenship or permanent residence of individuals taking the Firearm Training Course. Please refer to Attachment 1 on page 21 for a list of documents that serve as acceptable and unacceptable proof of citizenship or permanent residence.

### **2. Check registration / license status**

Private investigators, private patrol operators, security guards, alarm company operators and responding alarm agents are eligible to take the Firearm Training Course and, upon successful completion of the course, are eligible to receive a bureau issued firearm permit.

- If the student possesses a valid license or registration, record the license/registration number on the training roster.
- If the student does not possess a valid license or registration, proof of application or the intent of application must be presented. Proof can be presented in the form of an application, or copy of an application, that has been completed and signed by the applicant within one year of the date of the firearms training course.

### **3. Have state forms filled out (Complete application)**

Instructors are to complete the reverse side of the Application for Firearm Permit, under the section entitled "Certificate of Firearms Range Qualification," using one color ink. Students must complete the front page of the Application for Firearm Permit before submitting it to the bureau. The submission of incomplete or illegible forms may result in processing delays or the application being returned.

### **4. Have training school forms filled out (Complete training roster)**

Instructors are responsible for the completion of a training roster. Rosters must be typed or clearly printed and must contain the following information:

- The student's name
- The written examination score

- The range score
- The date of classroom instruction
- The date of range qualification
- The make and caliber of the qualifying firearm
- The instructor's name
- Information recording the passing or failure of the firearm training course

If a student fails to qualify, whether in the classroom or on the range, the score(s) must be recorded on the date(s) qualification was attempted. Rosters must be retained for a period of two years (Business and Professions Code Section 7585.7).

## **5. Course admission and discussion (Instructor Discussion)**

### **B. Laws and regulations for issuing a firearms qualification card – General information**

#### **PENAL CODE SECTION 832 TRAINING IS NOT ACCEPTED BY THE BUREAU OF SECURITY AND INVESTIGATIVE SERVICES (BUREAU) AND CANNOT BE USED AS SUBSTITUTE COURSE OF TRAINING:**

Penal Code Section 832 (PC 832) training is intended for and required of California peace officers. Security guards are NOT peace officers as defined by the Penal Code. Security guards are subject to the Business and Professions Code, specifically, Division 3, Business and Professions Code Chapter 11.5, Private Security Services Act. The primary role of the security guard is to Observe and Report. Therefore, because peace officer training is not appropriate for security guards, the Bureau does not recommend nor accept the training for security guards.

#### **FIREARM APPLICATION PROCESSING TIME / USE OF LIVSCAN RECOMMENDED:**

The approximate time frame to process an initial firearm permit application is generally between two and four months (approximately 60 to 120 days). Firearm requalification applications should be submitted to the bureau at least 60 days prior to the expiration date of the firearm permit.

Applicants are urged to use LIVSCAN rather than fingerprint cards to submit the fingerprints required for a firearm permit, as well as all other licensing, registration or permit applications. Live Scan is a process of electronic transmission of fingerprints rather than the manual submission of fingerprint cards.

The processing time may take longer if the applicant has a criminal record. If the guard first applied for and received a guard card then applied for a firearm permit, the guard may not carry a firearm while on duty until the firearm permit is issued by the bureau. The

guard must possess and carry a valid firearm permit in order to carry and use a firearm while on duty as a guard. If the firearm permit expires, the guard may not carry a firearm while on duty until the guard receives a new, valid firearm permit.

Instructors are to inform students that although they have paid the firearm course fees, successful completion of the course is not guaranteed. Students must establish to the instructor's satisfaction that they are proficient in the handling of the weapon and in meeting course requirements.

## **WEBSITE – INFORMATION AVAILABLE:**

**<http://bsis.ca.gov>**

A wide range of information is available on the bureau web-site at the above address. Available information includes licensing fees, applications, livescan forms, publications, and legislative updates.

## **FELONS, PROHIBITED MISDEMEANORS AND DOMESTIC VIOLENCE PROHIBITIONS:**

Instructors are to specifically inform each student that a firearm permit shall not be issued by the Bureau to a person who has been convicted of a felony or a misdemeanor that prohibits the person from carrying or possessing a firearm.

Specifically, the Bureau SHALL NOT issue a firearm permit to: A convicted felon (Business and Professions Code Section 7583.24(a); Penal Code Sections 29800, 29810, 29900, 29905), to a person convicted of a misdemeanor who is prohibited from possession of a firearm for a period of 10 years (Penal Code Section 29805 and 29810); nor to an individual with a history of domestic violence or who is subject to a Temporary Restraining Order (TRO) - (Penal Code Section 18250)

Students may also be denied a firearm permit if they have been convicted of a crime of violence (Penal Code Section 29905), such as assault, battery, assault with a deadly weapon, or a weapons violation, such as brandishing a weapon, illegal possession of and/or discharge of a weapon or carrying a concealed weapon without a concealed weapon permit.

## **QUALIFICATION AND PERMIT TO CARRY FIREARM BY CALIBER:**

Instructors are to clearly inform students that the caliber of ammunition that the student uses for range qualification is printed on the firearm permit. While on duty as a guard armed with a firearm, the guard can only carry a firearm of a caliber which is printed on their firearm permit.. A guard may NOT carry while on duty any caliber that is NOT printed on the permit.



A student may qualify with more than one caliber provided he/she passes the entire course of fire and qualifies on the range with each caliber the student wants printed on the firearm permit. For example, if a licensee/registrant wants to carry a 38 or 45 caliber while on duty, he/she must qualify on the range with a 38 and 45 caliber and submit that information to the Bureau.

The bureau will then issue a firearm permit which states the licensee/registrant may carry a 38 or 45 caliber. The licensee/registrant MUST then carry ONLY a 38 or 45 caliber while on duty. The licensee/registrant may not carry both a 38 and 45 caliber while on duty.

A person with a Bureau issued exposed firearm permit may carry an exposed firearm ONLY when performing the duties of his/her qualifying license or registration. The qualifying license or registration for an exposed firearm permit is a valid security guard registration, or private patrol operator's license, or private investigator license, or alarm company qualifying manager license, or alarm agent registration.

#### **IN ORDER TO CARRY AN EXPOSED FIREARM WHILE ON DUTY:**

A SECURITY GUARD MUST POSSESS BOTH A VALID SECURITY GUARD REGISTRATION AND A VALID FIREARM PERMIT.

AN ALARM AGENT MUST POSSESS BOTH A VALID ALARM AGENT REGISTRATION AND A VALID FIREARM PERMIT.

A PRIVATE INVESTIGATOR MUST HAVE PASSED THE PRIVATE INVESTIGATOR EXAMINATION, AND POSSESS BOTH A VALID PRIVATE INVESTIGATOR LICENSE AND A VALID FIREARM PERMIT.

A PRIVATE PATROL OPERATOR MUST HAVE PASSED THE PRIVATE PATROL OPERATOR EXAMINATION AND POSSESS BOTH A VALID PRIVATE PATROL OPERATOR LICENSE AND A VALID FIREARM PERMIT.

AN ALARM COMPANY OPERATOR MUST HAVE PASSED THE ALARM COMPANY OPERATOR EXAMINATION AND POSSESS BOTH A VALID ALARM COMPANY QUALIFIED MANAGER LICENSE AND A VALID FIREARM PERMIT.

#### **ACTIVE DUTY PEACE OFFICERS: CONCEALED WEAPONS AND EXEMPTIONS:**

An active duty peace officer may carry an exposed or concealed weapon while on duty as a security guard provided all of the following conditions are satisfied: The peace officer is employed as a security guard and is either on the pay-roll (paid on a W-2) of a private patrol operator (i.e. paid with a W-2), or is employed by a proprietary private security employer (i.e. such as in-house security) and is an employee (not a subcontractor) of the employer (i.e. a VIP being protected).

While on duty as an armed security guard, the peace officer must possess a guard registration card and an exposed weapon permit issued by the bureau. An active duty peace officer is not required to complete the Bureau's firearm course nor satisfy the bureau's twice-a-year range requalifications. An active duty or level I or II reserve peace officer is exempt from the training and the requalifying requirements as long as they are required to requalify with their law enforcement employer.

An active duty peace officer who **contracts** to provide armed security services **MUST** possess a private patrol operator's license issued by the bureau.

### **RETIRED PEACE OFFICERS – ENDORSEMENT TO CARRY A CONCEALED WEAPON:**

An honorably retired peace officer with an endorsement from a law enforcement agency to carry a concealed weapon may carry a concealed weapon while on **duty** as a private patrol operator (qualified manager), security guard, private investigator (qualified manager), alarm company qualified manager or alarm agent, provided that he/she has a valid private patrol operator license, security guard registration, private investigator license, alarm company qualified manager license or alarm agent registration, **and** a valid firearm permit issued by the bureau.

Retired peace officers **MUST** complete the bureau's course of fire **AND** the twice-a-year requalification requirements.

### **RESERVE PEACE OFFICERS:**

Reserve peace officers authorized and qualified by their agency to carry a firearm are exempt from completing the twice-a-year two-hour course review and range requalifications. Reserve peace officers not authorized and qualified to carry a firearm while on duty must complete the twice-a-year course review and the range requalifications (California Code of Regulations, Section 633(e)).

Reserve peace officers must submit proof from their agency that they are authorized and qualified to carry a firearm in order to be exempt from the requalification requirements.

### **TWO-HOUR REVIEW COURSE PRIOR TO RANGE REQUALIFICATION:**

Persons completing any of the twice-a-year range requalification must complete a two (2) hour review course prior to firing on the range (California Code of Regulations, Section 633c). The course review must be under the supervision of a certified firearm instructor, licensed private patrol operator (PPO), or a person designated by the PPO. The material for the review is provided in section II at C. **MORAL** and **LEGAL ASPECTS**,

CONFLICT SITUATIONS: DE-ESCALATION OF FORCE AND USE OF DEADLY FORCE. Specifically, the review shall focus on the use of deadly force and the avoidance of deadly force, including methods of de-escalation.

### **DENIAL OF RENEWAL APPLICATION: FAILURE TO COMPLETE REVIEW COURSE AND RANGE REQUALIFICATION:**

Failure to complete the twice-a-year course review and range requalification may result in the bureau denying the application to renew a firearm permit at the expiration of the two-year permit. If the bureau denies an application for a renewal of a firearm permit, the applicant must re-apply as an initial applicant for a new firearm permit. As a result, the applicant may not carry a firearm while on duty until the bureau issues a new firearm permit.

### **EXPIRED FIREARM PERMITS NOT VALID NOR RENEWABLE**

Expired firearm permits are not valid and can not be renewed. A guard with an expired firearm permit may not carry a firearm while on duty.

If a guard fails to apply for a renewal firearm permit prior to the expiration date on the permit, the guard must apply for a new firearm permit as an initial applicant and may not carry a firearm while on duty until a new firearm permit is issued by the bureau.

As of **January 1, 2013**, if a guard has successfully renewed the firearm permit but failed to receive an updated permit prior to the expiration date of the old permit, the guard may continue to carry a firearm while on duty **ONLY** if the guard carries on his or her person a hard copy print out of the bureau's approval of the renewal application from the bureau's internet website and a valid picture identification. (Business and Professions Code Section 7583.12(2)(b)). A guard who has lost his/her permit and has requested a new permit, or a guard who has been granted an initial permit and is waiting to receive it may also carry a firearm while on duty **ONLY** if the guard carries on his or her person a hard copy print out of the bureau's approval of the renewal application from the bureau's internet website and a valid picture identification

Any guard who does not comply with these requirements is subject to criminal prosecution and bureau discipline, such as the bureau denial of an application to renew a firearm permit.

Also, the Guard Company employing the guard with an expired firearm permit is subject to bureau discipline.

### **FIREARM ACCESSORIES**

California has many laws and regulations covering firearms and firearm accessories. Everyone must comply with these laws. Failure to comply with these laws may result in

an arrest, criminal prosecution, and a prison sentence and/or payment of a fine whether or not you possess a bureau issued exposed firearm permit. In addition, if you are convicted of violating any of these laws, you are subject to disciplinary action by the Bureau, such as revocation of your permit.

For example, there are specific types of firearms or accessories that are prohibited, such as extra large capacity magazines. These types of specific laws are not identified in this manual. There are two reasons for this. First, these laws are not in the domain of the bureau. Second, these laws are subject to change.

Nevertheless, if you possess a bureau issued exposed firearm permit, you are responsible for complying with these laws.

If you have any questions about these laws, contact your local law enforcement agency or the Department of Justice. These agencies, not the bureau, are generally responsible for regulating and enforcing the laws regarding prohibited firearms or accessories.

Active duty peace officers are advised to discuss this matter with their agency.

## ATTACHMENT I

### **STUDENTS MUST PROVIDE PROOF OF CITIZENSHIP OR LEGAL RESIDENCY PRIOR TO COURSE PARTICIPATION. THESE DOCUMENTS ARE ACCEPTABLE EVIDENCE OF UNITED STATES CITIZENSHIP OR PERMANENT RESIDENCE:**

1. Alien Registration Receipt Card [green card] (INS Form I-151 or AR-3a; issued by INS prior to June 1978). This card must contain a photograph of the bearer.
2. Permanent Resident Card [green card] (INS Form I-551, a revised edition of INS Form I-151). This card must contain a photograph of the bearer.
3. Certificate of Naturalization (INS Form N-550 or N-570). This certificate must contain a photograph of the bearer with a dry seal over the photograph.
4. United States Citizen Identification Card (INS Form I-197). INS no longer issues these cards, however, once issued, they do not expire). Must contain photo & physical description.

5. Identification Card for use of Resident Citizen in the United States (INS Form I-179). INS stopped issuing this card after 1977; however, once issued, they do not expire.
6. Certificate of United States Citizenship (INS Form N-560 or N-561).
7. Certificate of Birth abroad issued by the Department of State (Form FS-545 or form DS-1350).
8. Native American Tribal documents.
9. United States Military ID card or DD214, Geneva Convention Identification card for Active Military Person.
10. Report of Separation [military discharge] (Form DD-214).
11. Birth Certificate showing birth in the United States, American Samoa, District of Columbia, Guam, Northern Mariana Islands, Puerto Rico, Swains Island, or United States Virgin Islands.
12. United States Passport Book (unexpired) or United States Passport Card (unexpired).
13. Permit to Re-enter the United States (INS Form I-327).
14. Refugee or parolee documents only if accompanied by INS Form I-151, AR-3a, or I-551.

**THESE DOCUMENTS ARE NOT ACCEPTABLE AS EVIDENCE OF UNITED STATES CITIZENSHIP OR PERMANENT RESIDENCE**

1. Temporary Resident Card (INS Form I-688).  
**NOTE:** INSTRUCTORS MAY ACCEPT TEMPORARY RESIDENT CARD (INS FORM I-688) **IF** THE REVERSE SIDE OF THE CARD DISPLAYS A STICKER ISSUED BY THE IMMIGRATION AND NATURALIZATION SERVICE EVIDENCING TEMPORARY PROOF OF CITIZENSHIP OR PERMANENT RESIDENCE. THE STICKER BEARS THE SEAL OF THE DEPARTMENT OF JUSTICE.
2. Employment Authorization Card (INS Form I-688A, I-688B, and I-766).
3. Refugee or parolee documents unless accompanied by INS Form I-151, AR-3a, or I-151.
4. Employment Eligibility Verification (INS Form I-9).
5. Driver's License.
6. Social Security Card.

7. Foreign Passport.
8. Voter Registration.
9. School Identification Card.
10. Hospital Record.
11. Visas.
12. Arrival/Departure Record (INS Form I-94).

## **II. MORAL AND LEGAL ASPECTS**

### **A. Laws regarding possession and carrying of firearms. (Introduction to firearm use: Moral Aspects)**

The firearm training course is designed to teach students basic technical aspects and legal responsibilities inherent in carrying and using a firearm. Knowing how and when to use a firearm are both equally important. Knowing how to use the weapon may save your life. Knowing when to use the weapon may keep you from being criminally prosecuted and going to jail.

A firearm is a deadly weapon and a security guard may use a firearm while on duty only for defensive purposes. This means a guard may use a firearm **ONLY** if there is an eminent threat to the guard's life or to another person's life. This is the condition and responsibility a guard accepts if the guard carries and uses a firearm on duty. If the student can not comply with this condition and responsibility, then do not participate in this training course and do not carry a weapon on duty. A guard may be held responsible, criminally prosecuted and sentenced to prison for using a firearm on duty if there was not a clear and immediate threat to the guard's life or to another person's life. A primary

objective of firearm training is to clearly communicate that a firearm may be used only to protect and preserve life.

#### THE PROTECTION AND PRESERVATION OF LIFE – REQUIREMENTS FOR USE OF DEADLY FORCE:

- A firearm may be used only when there is a clear and present danger to life.
- A firearm may be used only when other defensive methods are inappropriate or have failed.

#### A FIREARM MUST NEVER BE USED FOR ANY OF THE FOLLOWING:

- To apprehend a fleeing suspect.
- To demonstrate authority.
- To psychologically "impress" others.
- As an aggressive or offensive weapon.

#### AVOID POTENTIAL DANGER AND DO NOT:

- Handle a firearm recklessly.
- Practice an unauthorized and unsafe "quick-draw."
- Draw a firearm to frighten someone.
- Fire a warning shot.
- Fire at suspicious objects (such as movement in a brush or in the direction of a strange noise).
- Fail to thoroughly examine the physical condition of all firearm parts, including ammunition.

A firearm may be used ONLY if there is an imminent danger of death or serious bodily injury to the guard or to another person and there is no other option available to avoid or neutralize the danger.

Each student is expected to be familiar with each section of this manual. The instructor is expected to adequately cover each section to assure that the student has had the opportunity to review and understand the material, the law, and what consequences may follow for violating the law.

### **LEGAL RESTRICTIONS, STATUTES, CODES, REGULATIONS AND INSTRUCTOR EXAMPLES**

#### **1. PENAL CODE SECTIONS**

##### **CARRYING A LOADED FIREARM**

**§25850(a)**

A person is guilty of carrying a loaded firearm when the person carries a loaded firearm on the person or in a vehicle while in any public place or on any public street in an incorporated city or in any public place or on any public street in a prohibited area of unincorporated territory.

**§26030(a)**

Section 25850 does not apply to any of the following who have been issued a certificate pursuant to subdivision (d):

(1) Guards or messengers of common carriers, banks, and other financial institutions, while actually employed in and about the shipment, transportation, or delivery of any money, treasure, bullion, bonds, or other thing of value within this state.

(2) Guards of contract carriers operating armored vehicles pursuant to California Highway Patrol and Public Utilities Commission authority, if they were hired prior to January 1, 1977.

(3) Guards of contract carriers operating armored vehicles pursuant to California Highway Patrol and Public Utilities Commission authority, if they were hired on or after January 1, 1977, and they have completed a course in the carrying and use of firearms that meets the standards prescribed by the Department of Consumer Affairs.

(4) Private investigators licensed pursuant to Chapter 11.3 (commencing with Section 7512) of Division 3 of the Business and Professions Code, while acting within the course and scope of their employment.

(5) Uniformed employees of private investigators licensed pursuant to Chapter 11.3 (commencing with Section 7512) of Division 3 of the Business and Professions Code, while acting within the course and scope of their employment.

(6) Private patrol operators licensed pursuant to Chapter 11.5 (commencing with Section 7580) of Division 3 of the Business and Professions Code, while acting within the course and scope of their employment.

(7) Uniformed employees of private patrol operators licensed pursuant to Chapter 11.5 (commencing with Section 7580) of Division 3 of the Business and Professions Code, while acting within the course and scope of their employment.

(8) Alarm company operators licensed pursuant to Chapter 11.6 (commencing with Section 7590) of Division 3 of the Business and Professions Code, while acting within the course and scope of their employment.

(9) Uniformed security guards or night watch persons employed by any public agency, while acting within the scope and course of their employment.

(10) Uniformed security guards, regularly employed and compensated in that capacity by persons engaged in any lawful business, and uniformed alarm agents employed by an alarm company operator, while actually engaged in protecting and preserving the property of their employers, or on duty or en route to or from their residences or their places of employment, and security guards and alarm agents en route to or from their residences or employer-required range training.



## **Instructor Explanation: Possession of Valid Firearm Permit Required to Carry Firearm On Duty**

Instructors are to inform students that the term “in the course and scope of their employment” also requires the guard to possess a valid firearm permit. A security guard who does not carry a valid firearm permit while armed and on duty with a weapon is subject to arrest for unlawfully carrying a firearm. Possession of a guard registration and exposed firearm permit does not permit a security guard to carry a firearm while off duty, unless the guard is traveling to or from his/her residence, work site or firearm range. During travel, the gun must be unloaded and kept in a locked container.

The completion of this course is NOT sufficient for a person to carry a firearm on duty, whether exposed or concealed. While on duty as a guard armed with a firearm, the guard must be in possession of a valid firearm permit. In addition, the guard can only carry a firearm of a caliber with which he/she has qualified for on the range and which is printed on his/her firearm permit. An individual who carries a firearm on duty without having received the bureau firearm permit is in violation of this requirement and subject to criminal prosecution and denial or revocation of the firearm permit by the Bureau.

A security guard, or body guard, who carries a concealed weapon while on duty in civilian clothes must possess and carry both the guard registration card and exposed firearm permit, issued by the Bureau, AND satisfy one of the following three requirements: (1) possess a concealed weapons permit (CCW) issued by a local law enforcement agency; or (2) be an active duty peace officer employed as a security guard/bodyguard by a private patrol operator, or by the person or the entity being protected; or (3) be an honorably retired peace officer, with an endorsement to carry a concealed weapon, and employed as a security guard/bodyguard by a private patrol operator, or by the person or entity being protected.

### **TRANSPORTATION OF A FIREARM**

#### **§25505**

In order for a firearm to be exempted under this article, while being transported to or from a place, the firearm shall be unloaded and kept in a locked container, and the course of travel shall include only those deviations between authorized locations as are reasonably necessary under the circumstances.

#### **§25540**

Section 25400 does not apply to, or affect, the transportation of a firearm by a person when going directly to, or coming directly from, a target range, which holds a regulatory or business license, for the purposes of practicing shooting at targets with that firearm at the target range.

### **FELONS MAY NOT POSSESS A FIREARM**

### **§29800**

(a)(1) Any person who has been convicted of a felony under the laws of the United States, of the State of California, or any other state, government, or country, or of an offense enumerated in subdivision (a), (b), or (d) of Section 12001.6, or who is addicted to the use of any narcotic drug, and who owns, purchases, receives, or has in his or her possession or under his or her custody or control any firearm is guilty of a felony.

### **§29805.**

Except as provided in Section 29855 or subdivision (a) of Section 29800, any person who has been convicted of a misdemeanor violation of Section 71, 76, 136.1, 136.5, or 140, subdivision (d) of Section 148, Section 171b, paragraph (1) of subdivision (a) of Section 171c, 171d, 186.28, 240, 241, 242, 243, 243.4, 244.5, 245, 245.5, 246.3, 247, 273.5, 273.6, 417, 417.6, 422, 626.9, 646.9, or 830.95, subdivision (a) of former Section 12100, as that section read at any time from when it was enacted by Section 3 of Chapter 1386 of the Statutes of 1988 to when it was repealed by Section 18 of Chapter 23 of the Statutes of 1994, Section 17500, 17510, 25300, 25800, 30315, or 32625, subdivision (b) or (d) of Section 26100, or Section 27510, or Section 8100, 8101, or 8103 of the Welfare and Institutions Code, any firearm-related offense pursuant to Sections 871.5 and 1001.5 of the Welfare and Institutions Code, or of the conduct punished in subdivision (c) of Section 27590, and who, within 10 years of the conviction, owns, purchases, receives, or has in possession or under custody or control, any firearm is guilty of a public offense, which shall be punishable by imprisonment in a county jail not exceeding one year or in the state prison, by a fine not exceeding one thousand dollars (\$1,000), or by both that imprisonment and fine. The court, on forms prescribed by the Department of Justice, shall notify the department of persons subject to this section. However, the prohibition in this section may be reduced, eliminated, or conditioned as provided in Section 29855 or 29860.

### **§29810**

(a) For any person who is subject to Section 29800 or 29805, the court shall, at the time judgment is imposed, provide on a form supplied by the Department of Justice, a notice to the defendant prohibited by this chapter from owning, purchasing, receiving, possessing, or having under custody or control, any firearm. The notice shall inform the defendant of the prohibition regarding firearms and include a form to facilitate the transfer of firearms.

(b) Failure to provide the notice described in subdivision (a) shall not be a defense to a violation of this chapter.

### **§29815**

(a) Any person who, as an express condition of probation, is prohibited or restricted from owning, possessing, controlling, receiving, or purchasing a firearm and who owns, purchases, receives, or has in possession or under custody or

control, any firearm, but who is not subject to Section 29805 or subdivision (a) of Section 29800, is guilty of a public offense, which shall be punishable by imprisonment in a county jail not exceeding one year or in the state prison, by a fine not exceeding one thousand dollars (\$1,000), or by both that imprisonment and fine.

(b) The court, on forms provided by the Department of Justice, shall notify the department of persons subject to this section. The notice shall include a copy of the order of probation and a copy of any minute order or abstract reflecting the order and conditions of probation.

#### **§29900.**

(a) (1) Notwithstanding subdivision (a) of Section 29800, any person who has been previously convicted of any of the offenses listed in Section 29905 and who owns or has in possession or under custody or control any firearm is guilty of a felony.

(2) A dismissal of an accusatory pleading pursuant to Section 1203.4a involving an offense set forth in Section 29905 does not affect the finding of a previous conviction.

(3) If probation is granted, or if the imposition or execution of sentence is suspended, it shall be a condition of the probation or suspension that the defendant serve at least six months in a county jail.

(b) (1) Any person previously convicted of any of the offenses listed in Section 29905 which conviction results from certification by the juvenile court for prosecution as an adult in adult court under the provisions of Section 707 of the Welfare and Institutions Code, who owns or has in possession or under custody or control any firearm, is guilty of a felony.

(2) If probation is granted, or if the imposition or execution of sentence is suspended, it shall be a condition of the probation or suspension that the defendant serve at least six months in a county jail.

(c) The court shall apply the minimum sentence as specified in subdivisions (a) and (b) except in unusual cases where the interests of justice would best be served by granting probation or suspending the imposition or execution of sentence without the imprisonment required by subdivisions (a) and (b), or by granting probation or suspending the imposition or execution of sentence with conditions other than those set forth in subdivisions (a) and (b), in which case the court shall specify on the record and shall enter on the minutes the circumstances indicating that the interests of justice would best be served by the disposition.

#### **§29905.**

(a) As used in this chapter, a violent offense includes any of the following:

(1) Murder or voluntary manslaughter.

(2) Mayhem.

(3) Rape.

(4) Sodomy by force, violence, duress, menace, or threat of great bodily harm.

(5) Oral copulation by force, violence, duress, menace, or threat of great bodily harm.

(6) Lewd acts on a child under the age of 14 years.

(7) Any felony punishable by death or imprisonment in the state prison for life.

(8) Any other felony in which the defendant inflicts great bodily injury on any person, other than an accomplice, that has been charged and proven, or any felony in which the defendant uses a firearm which use has been charged and proven.

(9) Attempted murder.

(10) Assault with intent to commit rape or robbery.

(11) Assault with a deadly weapon or instrument on a peace officer.

(12) Assault by a life prisoner on a nominate.

(13) Assault with a deadly weapon by an inmate.

(14) Arson.

(15) Exploding a destructive device or any explosive with intent to injure.

(16) Exploding a destructive device or any explosive causing great bodily injury.

(17) Exploding a destructive device or any explosive with intent to murder.

(18) Robbery.

(19) Kidnapping.

(20) Taking of a hostage by an inmate of a state prison.

(21) Attempt to commit a felony punishable by death or imprisonment in the state prison for life.

(22) Any felony in which the defendant personally used a dangerous or deadly weapon.

(23) Escape from a state prison by use of force or violence.

(24) Assault with a deadly weapon or force likely to produce great bodily injury.

(25) Any felony violation of Section 186.22.

(26) Any offense enumerated in subdivision (a), (b), or (d) of Section 23515.

(27) Carjacking.

(28) Any offense enumerated in subdivision (c) of Section 23515 if the person has two or more convictions for violating paragraph (2) of subdivision (a) of Section 417.

(b) As used in this chapter, a violent offense also includes any attempt to commit a crime listed in subdivision (a) other than an assault.

### **§23515**

As used in the provisions listed in Section 16580, an offense that involves the violent use of a firearm includes any of the following:

(a) A violation of paragraph (2) or (3) of subdivision (a) of Section 245 or a violation of subdivision (d) of Section 245.

(b) A violation of Section 246.

(c) A violation of paragraph (2) of subdivision (a) of Section 417.

(d) A violation of subdivision (c) of Section 417.

## §245

(a)(2) Any person who commits an assault upon the person of another with a firearm shall be punished by imprisonment in the state prison for two, three, or four years, or in a county jail for not less than six months and not exceeding one year, or by both a fine not exceeding ten thousand dollars (\$10,000) and imprisonment.

(3) Any person who commits an assault upon the person of another with a machinegun, as defined in Section 16880, or an assault weapon, as defined in Section 30510 or 30515, or a .50 BMG rifle, as defined in Section 30530, shall be punished by imprisonment in the state prison for 4, 8, or 12 years.

(4) Any person who commits an assault upon the person of another by any means of force likely to produce great bodily injury shall be punished by imprisonment in the state prison for two, three, or four years, or in a county jail for not exceeding one year, or by a fine not exceeding ten thousand dollars (\$10,000), or by both the fine and imprisonment.

(d)(1) Any person who commits an assault with a firearm upon the person of a peace officer or firefighter, and who knows or reasonably should know that the victim is a peace officer or firefighter engaged in the performance of his or her duties, when the peace officer or firefighter is engaged in the performance of his or her duties, shall be punished by imprisonment in the state prison for four, six, or eight years.

(2) Any person who commits an assault upon the person of a peace officer or firefighter with a semiautomatic firearm and who knows or reasonably should know that the victim is a peace officer or firefighter engaged in the performance of his or her duties, when the peace officer or firefighter is engaged in the performance of his or her duties, shall be punished by imprisonment in the state prison for five, seven, or nine years.

(3) Any person who commits an assault with a machinegun, as defined in Section 16880, or an assault weapon, as defined in Section 30510 or 30515, or a .50 BMG rifle, as defined in Section 30530, upon the person of a peace officer or firefighter, and who knows or reasonably should know that the victim is a peace officer or firefighter engaged in the performance of his or her duties, shall be punished by imprisonment in the state prison for 6, 9, or 12 years.

## §246

Any person who shall maliciously and willfully discharge a firearm at an inhabited dwelling house, occupied building, occupied motor vehicle, occupied aircraft, inhabited house car, as defined in Section 362 of the Vehicle Code, or inhabited camper, as defined in Section 243 of the Vehicle Code, is guilty of a felony, and upon conviction shall be punished by imprisonment in the state prison for three, five, or seven years, or by imprisonment in the county jail for a term of not less than six months and not exceeding one year.

As used in this section, "inhabited" means currently being used for dwelling purposes, whether occupied or not.

## **§417**

(a)(2) Every person who, except in self-defense, in the presence of any other person, draws or exhibits any firearm, whether loaded or unloaded, in a rude, angry, or threatening manner, or who in any manner, unlawfully uses a firearm in any fight or quarrel is punishable as follows:

(A) If the violation occurs in a public place and the firearm is a pistol, revolver, or other firearm capable of being concealed upon the person, by imprisonment in a county jail for not less than three months and not more than one year, by a fine not to exceed one thousand dollars (\$1,000), or by both that fine and imprisonment.

(B) In all cases other than that set forth in subparagraph (A), a misdemeanor, punishable by imprisonment in a county jail for not less than three months.

(c) Every person who, in the immediate presence of a peace officer, draws or exhibits any firearm, whether loaded or unloaded, in a rude, angry, or threatening manner, and who knows, or reasonably should know, by the officer's uniformed appearance or other action of identification by the officer, that he or she is a peace officer engaged in the performance of his or her duties, and that peace officer is engaged in the performance of his or her duties, shall be punished by imprisonment in a county jail for not less than nine months and not to exceed one year, or in the state prison for 16 months, or two or three years.

### **Instructor Explanation: Prohibited factors**

The Bureau is prohibited from issuing a firearm permit to any person convicted of violating any of the above sections of the Penal Code. Any person convicted of a prohibitive misdemeanor, a felony, or the violent use of a firearm anywhere in the United States is prohibited both from possessing a firearm and from being issued a firearm permit by the Bureau. A felony conviction prohibits the felon from possessing a firearm and the Bureau from issuing a firearm permit, no matter how many years have passed.

### **CONCEALED WEAPON IN VEHICLE OR ON PERSON**

## **§25400**

(a) A person is guilty of carrying a concealed firearm when the person does any of the following:

(1) Carries concealed within any vehicle that is under the person's control or direction any pistol, revolver, or other firearm capable of being concealed upon the person.

(2) Carries concealed upon the person any pistol, revolver, or other firearm capable of being concealed upon the person.

(3) Causes to be carried concealed within any vehicle in which the person is an occupant any pistol, revolver, or other firearm capable of being concealed upon the person.

(b) A firearm carried openly in a belt holster is not concealed within the meaning of this section.

(c) Carrying a concealed firearm in violation of this section is punishable as follows:

(1) If the person previously has been convicted of any felony, or of any crime made punishable by a provision listed in Section 16580, as a felony.

(2) If the firearm is stolen and the person knew or had reasonable cause to believe that it was stolen, as a felony.

(3) If the person is an active participant in a criminal street gang, as defined in subdivision (a) of Section 186.22, under the Street Terrorism Enforcement and Prevention Act (Chapter 11(commencing with Section 186.20) of Title 7 of Part 1), as a felony.

(4) If the person is not in lawful possession of the firearm or the person is within a class of persons prohibited from possessing or acquiring a firearm pursuant to Chapter 2 (commencing with Section 29800) or Chapter 3 (commencing with Section 29900) of Division 9 of this title, or Section 8100 or 8103 of the Welfare and Institutions Code, as a felony.

(5) If the person has been convicted of a crime against a person or property, or of a narcotics or dangerous drug violation, by imprisonment pursuant to subdivision (h) of Section 1170, or by imprisonment in a county jail not to exceed one year, by a fine not to exceed one thousand dollars (\$1,000), or by both that imprisonment and fine.

(6) If both of the following conditions are met, by imprisonment pursuant to subdivision (h) of Section 1170, or by imprisonment in a county jail not to exceed one year, by a fine not to exceed one thousand dollars (\$1,000), or by both that fine and imprisonment:

(A) The pistol, revolver, or other firearm capable of being concealed upon the person is loaded, or both it and the unexpended ammunition capable of being discharged from it are in the immediate possession of the person or readily accessible to that person.

(B) The person is not listed with the Department of Justice pursuant to paragraph (1) of subdivision (c) of Section 11106 as the registered owner of that pistol, revolver, or other firearm capable of being concealed upon the person.

(7) In all cases other than those specified in paragraphs (1) to (6), inclusive, by imprisonment in a county jail not to exceed one year, by a fine not to exceed one thousand dollars (\$1,000), or by both that imprisonment and fine.

(d) (1) Every person convicted under this section who previously has been convicted of a misdemeanor offense enumerated in Section 23515 shall be punished by imprisonment in a county jail for at least three months and not exceeding six months, or, if granted probation, or if the execution or imposition of sentence is suspended, it shall be a condition thereof that the person be imprisoned in a county jail for at least three months.

(2) Every person convicted under this section who has previously been convicted of any felony, or of any crime made punishable by a provision listed in Section 16580, if probation is granted, or if the execution or imposition of sentence is

suspended, it shall be a condition thereof that the person be imprisoned in a county jail for not less than three months.

(e) The court shall apply the three-month minimum sentence as specified in subdivision (d), except in unusual cases where the interests of justice would best be served by granting probation or suspending the imposition or execution of sentence without the minimum imprisonment required in subdivision (d) or by granting

probation or suspending the imposition or execution of sentence with conditions other than those set forth in subdivision (d), in which case, the court shall specify on the record and shall enter on the minutes the circumstances indicating that the interests of justice would best be served by that disposition.

(f) A peace officer may arrest a person for a violation of paragraph (6) of subdivision (c) if the peace officer has probable cause to believe that the person is not listed with the Department of Justice pursuant to paragraph (1) of subdivision (c) of Section 11106 as the registered owner of the pistol, revolver, or other firearm capable of being concealed upon the person, and one or more of the conditions in subparagraph (A) of paragraph (6) of subdivision (c) is met.

**Instructor Explanation: Exposed Weapon Permits and Concealed Weapons Permit**

The bureau issues exposed firearm permits. The Bureau does NOT issue concealed weapon permits (a CCW). The firearm permit issued by the Bureau is therefore not a concealed weapon permit. In order for a person to carry a concealed firearm as a security guard or private patrol operator, alarm agent, or private investigator, that person must possess a Bureau issued security guard registration and a bureau issued exposed firearm permit, AND meet one of the following three requirements: (1) possess a concealed weapon permit issued by a local law enforcement agency; or (2) be an active duty peace officer; or (3) be an honorably retired peace officer with an endorsement to carry a concealed weapon.

**EXEMPTIONS TO PENAL CODE SECTION 25400**

**§25605**

(a) Section 25400 and Chapter 6 (commencing with Section 26350) of Division 5 shall not apply to or affect any citizen of the United States or legal resident over the age of 18 years who resides or is temporarily within this state, and who is not within the excepted classes prescribed by Chapter 2 (commencing with Section 29800) or Chapter 3 (commencing with Section 29900) of Division 9 of this title, or Section 8100 or 8103 of the Welfare and Institutions Code, who carries, either openly or concealed, anywhere within the citizen's or legal resident's place of residence, place of business, or on private property owned or lawfully possessed by the citizen or legal resident, any handgun.

(b) No permit or license to purchase, own, possess, keep, or carry, either openly or concealed, shall be required of any citizen of the United States or legal resident over the age of 18 years who resides or is temporarily within this state,



and who is not within the excepted classes prescribed by Chapter 2 (commencing with Section 29800) or Chapter 3 (commencing with Section 29900) of Division 9 of this title, or Section 8100 or 8103 of the Welfare and Institutions Code, to purchase, own, possess, keep, or carry, either openly or concealed, a handgun within the citizen's or legal resident's place of residence, place of business, or on private property owned or lawfully possessed by the citizen or legal resident.

(c) Nothing in this section shall be construed as affecting the application of Sections 25850 to 26055, inclusive.

### **Instructor Explanation: Exemption**

The above section applies only to weapons in the home, place of business or other privately owned or lawfully possessed property. This means, for example, that a licensed Private Patrol Operator, who owns his or her business, may keep a firearm in the home or on business premises. However, neither the Operator nor the guard employees may carry an exposed firearm on duty without possessing a guard card and a firearm permit issued by the Bureau.

## **DRAWING OR EXHIBITING WEAPON**

### **§417**

(a) (1) Every person who, except in self-defense, in the presence of any other person, draws or exhibits any deadly weapon whatsoever, other than a firearm, in a rude, angry, or threatening manner, or who in any manner, unlawfully uses a deadly weapon other than a firearm in any fight or quarrel is guilty of a misdemeanor, punishable by imprisonment in a county jail for not less than 30 days.

(2) Every person who, except in self-defense, in the presence of any other person, draws or exhibits any firearm, whether loaded or unloaded, in a rude, angry or threatening manner, or who in any manner, unlawfully uses a firearm in any fight or quarrel is punishable as follows:

(B) (c) Every person who, in the immediate presence of a peace officer, draws or exhibits any firearm, whether loaded or unloaded, in a rude, angry or threatening manner, and who knows or reasonably should know, by the officer's uniformed appearance or other action of identification by the officer, that he or she is a peace officer engaged in the performance of his or her duties, and that peace officer is engaged in the performance of his or her duties, shall be punished by imprisonment in a county jail for not less than nine months and not to exceed one year, or in the state prison for 16 months, or two or three years.

(e) As used in this section, “peace officer” means any person designated as a peace officer pursuant to Chapter 4.5 (commencing with Section 830 of the Penal Code) of Title 3 of Part 2

### **Instructor Example/Explanation**

In a conflict situation while on duty, a guard must have just cause to remove the weapon from the holster. Just cause is defined as an imminent danger to life. The guard may not remove the weapon for any other reason, such as to threaten, intimidate, demonstrate authority, or impress another person.

### **ASSAULT**

#### **§240**

An assault is an unlawful attempt, coupled with a present ability, to commit a violent injury on the person of another. (Enacted 1872)

### **BATTERY**

#### **§242**

A battery is any willful and unlawful use of force or violence upon the person of another. (Enacted 1872)

### **ASSAULT WITH A DEADLY WEAPON**

#### **§245**

(a) (1) Any person who commits an assault upon the person of another with a deadly weapon or instrument other than a firearm or by any means of force likely to produce great bodily injury shall be punished by imprisonment in the state prison for two, three or four years, or in a county jail not exceeding one year, or by fine not exceeding ten thousand dollars (\$10,000), or by both the fine and imprisonment.

(2) Any person who commits an assault upon the person of another with a firearm is punishable by imprisonment in the state prison for two, three, or four years, or in a county jail for not less than six months and not exceeding one year, or by both a fine not exceeding ten thousand dollars (\$10,000) and imprisonment.

(e) When a person is convicted of a violation of this section, in a case involving use of a deadly weapon or instrument or firearm, and the weapon or instrument or firearm is owned by that person, the court shall order that the weapon or instrument or firearm be deemed a nuisance and it shall be confiscated and disposed of in the manner provided by Sections 18000 and 18005.

## JUSTIFIABLE HOMICIDE BY CIVILIAN

### §197

Homicide is also justifiable when committed by any person in any of the following cases:

1. When resisting any attempt to murder any person, or to commit a felony, or to do some great bodily injury upon any person; or,
2. When committed in defense of habitation, property, or person, against one who manifestly intends or endeavors, by violence or surprise, to commit a felony, or against one who manifestly intends and endeavors, in a violent, riotous or tumultuous manner, to enter the habitation of another for the purpose of offering violence to any person therein; or,
3. When committed in the lawful defense of such person, or of a wife or husband, parent, child, master, mistress, or servant of such person, when there is reasonable ground to apprehend a design to commit a felony or to do some great bodily injury, and imminent danger of such design being accomplished; but such person, or the person in whose behalf the defense was made, if he was the assailant or engaged in mutual combat, must really and in good faith have endeavored to decline any further struggle before the homicide was committed; or,
4. When necessarily committed in attempting, by lawful ways and means, to apprehend any person for any felony committed, or in lawfully suppressing any riot, or in lawfully keeping and preserving the peace.

### **Instructor Explanation: Justifiable Homicide Requires Real Threat**

Students are to be informed that while the law states that homicide may be justifiable when apprehending a felon other factors also apply. The felon must have committed an atrocious crime involving the use of force and there must be a real threat of death or great bodily harm. The following case law explains how courts interpret justifiable homicide:

*In People vs. Ceballos (1974), 12 CalApp.3d 470, the court held that homicide or the use of deadly force was justified only if the “felony” or “offense” contemplated by the statutes constituted a “forcible or atrocious” crime at common law. The Ceballos court explained that the justifiable homicide statute must be read in the light of the common law rule that, ordinarily deadly force could not be used for the sole purpose of protecting property. The Ceballos court held that homicide is justifiable when resisting any attempt to murder any person, or when committed in defense of habitation, property, or person, against one whom manifestly intends or endeavors, by violence or surprise, to commit a felony. The Ceballos court went on to conclude that burglary does not under all circumstances, constitute a forcible and atrocious crime such as will justify killing to prevent its commission.*

*In People vs. Piorkowski (1974), 41 CalApp.3d 324, the court held that even though the felon had committed a burglary, the use of deadly force to effect the arrest was not warranted, and the felon’s death during the course of arrest was not justified because the crime committed by the felon was not of the type which normally threatened death or great bodily harm since it*

*was committed during the daylight hours and in a business establishment which was open to the public and no confrontation aided by force was involved.*

Because the same laws which apply to private citizens apply also to security guards, if a security guard shoots a fleeing suspect, he or she will be prosecuted accordingly. It will only be considered justified if these factors apply.

## MANSLAUGHTER

### §192

Manslaughter is the unlawful killing of a human being without malice. It is in three kinds:

(a) Voluntary--upon a sudden quarrel or heat of passion.

(b) Involuntary--in the commission of an unlawful act, not amounting to felony; or in the commission of a lawful act which might produce death, in an unlawful manner, or without due caution and circumspection. This subdivision shall not apply to acts committed in the driving of a vehicle.

### BARE FEAR IS NOT A JUSTIFIABLE EXCUSE TO COMMIT HOMICIDE

### §198

A bare fear of the commission of any of the offenses mentioned in subdivisions 2 and 3 of Section 197, to prevent which homicide may be lawfully committed, is not sufficient to justify it. But the circumstances must be sufficient to excite the fears of a reasonable person, and the party killing must have acted under the influence of such fears alone.

### §198.5

Any person using force intended or likely to cause death or great bodily injury within his or her residence shall be presumed to have held a reasonable fear of imminent peril of death or great injury to self, family, or a member of the household when that force is used against another person, not a member of the family or household, who unlawfully and forcibly enters or has unlawfully and forcibly entered the residence and the person using the force knew or had reason to believe that an unlawful and forcible entry occurred.

As used in this section great bodily injury means a significant or substantial physical injury.

### **Instructor Discussion**

The instructor will discuss with the students that killing an individual because of a belief that the person may pose a future threat is not sufficient justification for homicide. There must also be a clear and present danger.

## **2. GOVERNMENT CODE SECTIONS - Business and Professions Code Sections Statutes of the Bureau of Security and Investigative Services**

## REQUIREMENTS FOR CARRYING A FIREARM

### §7583.5

(a) Every licensee and any person employed and compensated by a licensee, other lawful business or public agency as a security guard or patrol person, and who in the course of that employment or business carries a firearm, shall complete a course of training in the exercise of the powers to arrest and a course of training in the carrying and use of firearms. This subdivision shall not apply to armored vehicle guards hired prior to January 1, 1977. Armored vehicle guards hired on or after January 1, 1977, shall complete a course of training in the carrying and use of firearms, but shall not be required to complete a course of training in the exercise of the powers to arrest. The course of training in the carrying and use of firearms shall not be required of any employee who is not required or permitted by a licensee to carry or use firearms. The course in the carrying and use of firearms and the course of training in the exercise of the powers to arrest shall meet the standards which shall be prescribed by the Department of Consumer Affairs. The department shall encourage restraint and caution in the use of firearms.

(b) No uniformed employee of a licensee shall carry or use any firearm unless the employee has in his or her possession a valid firearm qualification card.

### §7583.3

No person required to be registered as a security guard pursuant to this chapter shall do any of the following:

(a) Fail to carry on his or her person, while on duty, a valid and current security guard registration card.

(b) Fail to carry on his or her person a valid and current firearms permit when carrying a firearm on duty.

(c) Carry or use a firearm unless he or she possesses a valid and current firearms permit issued pursuant to this chapter.

(d) Fail to report to his or her employer within 24 hours of the incident the circumstances surrounding any incident involving the discharge of any firearm in which he or she is involved while acting within the course and scope of his or her employment.

### §7583.4

Any person registered as a security guard or patrol person shall deliver to the director a written report describing fully the circumstances surrounding any incident involving the discharge of any firearm in which he or she was involved while acting within the course and scope of his or her employment, within seven days after the incident. The report shall be made on a form prescribed by the director which shall include, but not be limited to, the following:

(a) The name, address, and date of birth of the guard or patrol person.

(b) The registration number of the guard or patrol person.

- (c) The firearm permit number and baton permit number of the guard or patrol person, if applicable.
- (d) The name of the employer of the person.
- (e) The description of any injuries and damages that occurred.
- (f) The identity of all participants in the incident.
- (g) Whether a police investigation was conducted relating to the incident.
- (h) The date and location of the incident. Any report may be investigated by the director to determine if any disciplinary action is necessary.

A copy of the report delivered to the director pursuant to this section shall also be delivered within seven days of the incident to the local police or sheriff's department, which has jurisdiction over the geographic area where the incident occurred.

### **Instructor Explanation**

The instructor is to inform students that a registrant with a firearm permit must report in writing the discharge of a weapon. Failure to report the discharge may result in the Bureau imposing disciplinary action, such as a fine. (Business and Professions Code Sections 7587.9(d) and 7599.42)

### **§7583.12**

- (a) No employee of a licensee shall carry or use a firearm unless the employee has in his or her possession both of the following:
  - (1) A valid guard registration card issued pursuant to this chapter.
  - (2) A valid firearm qualification card issued pursuant to this chapter.
- (b) Paragraph (2) of subdivision (a) shall not apply to a duly appointed peace officer, as defined in Chapter 4.5 (commencing with Section 830) of Title 3 of Part 2 of the Penal Code, who meets all of the following:
  - (1) He or she has successfully completed a course of study in the use of arms
  - (2) He or she is authorized to carry a concealed firearm in the course and scope of his or her employment pursuant to Article 2 9(commencing with Section 25450) of Chapter 2 of Division 5 of Title 4 of Part 6 of the Penal Code.
  - (3) He or she has proof that he or she has applied to the bureau for a firearms qualification card.

### **§7583.12 (effective January 1, 2013)**

- (a) No employee of a licensee shall carry or use a firearm unless the employee has in his or her possession both of the following:
  - (1) A valid guard registration card issued pursuant to this chapter.
  - (2) A valid firearm qualification card issued pursuant to this chapter.
- (b) An employee of a licensee may carry or use a firearm while working as a security guard of security patrolperson pending receipt of a firearm qualification

card if he or she has been approved by the bureau and carries on his or her person a hardcopy printout of the bureau's approval from the bureau's Internet Web site and a valid picture identification.

(c) In the event of the loss or destruction of the firearm qualification card, the cardholder may apply to the bureau for a certified replacement of the card, stating the circumstances surrounding the loss, and pay a ten-dollar (\$10) certification fee, whereupon the bureau shall issue a certified replacement of the card

(d) Paragraph (2) of subdivision (a) shall not apply to a duly appointed peace officer, as defined in Chapter 4.5 (commencing with Section 830) of Title 3 of Part 2 of the Penal Code, who meets all of the following:

(1) He or she has successfully completed a course of study in the use of arms

(2) He or she is authorized to carry a concealed firearm in the course and scope of his or her employment pursuant to Article 29commencing with Section 25450) of Chapter 2 of Division 5 of Title 4 of Part 6 of the Penal Code.

(3) He or she has proof that he or she has applied to the bureau for a firearms qualification card.

#### **§7583.22**

(a) A licensee, qualified manager of a licensee, or security guard who in the course of his or her employment may be required to carry a firearm shall, prior to carrying a firearm, do both of the following:

(1) Complete a course of training in the carrying and use of firearms.

(2) Receive a firearms qualification card prior to carrying a firearm or be otherwise qualified to carry a firearm as provided in section 7583.12

(b) A licensee shall not permit an employee to carry or use a loaded or unloaded firearm, whether or not it is serviceable or operative, unless the employee possesses a valid and current firearms qualification and issued by the bureau or is so otherwise qualified to carry a firearm as provided in Section 7583.12

#### **Instructor Explanation**

Instructors are to inform students that employers who allow their employees to carry a firearm without possessing a valid firearm permit are subject to disciplinary action, such as a fine, for each employee who carries a firearm without a permit. Security guards are also subject to disciplinary action, such as fines; and subject to criminal prosecution and conviction under Section 25850 of the Penal Code. (Business and Professions Code Sections 7587.8(e); 7587.9(b) and 7599.40.)

#### **§7583.37**

The director [of the Department of Consumer Affairs] may assess fines as enumerated in Article 7 (commencing with Section 7587). Assessment of administrative fines shall be independent of any other action by the bureau or any local, state, or federal governmental agency which may result from a violation of this article. In addition to other prohibited acts under this chapter, no licensee,

qualified manager, or registered security guard shall, during the course and scope of licensed activity, do any of the following:

(a) Carry any inoperable, replica, or other simulated firearm.

(b) Use a firearm in violation of the law, or in knowing violation of the standards for the carrying and usage of firearms as taught in the course of training in the carrying and use of firearms. Such unlawful or prohibited uses of firearms shall include, but not be limited to, the following:

(1) Illegally using, carrying, or possessing a dangerous weapon.

(2) Brandishing a weapon.

(3) Drawing a weapon without proper cause.

(4) Provoking a shooting incident without cause.

(5) Carrying or using a firearm while on duty under the influence of alcohol or dangerous drugs.

(6) Carrying or using a firearm of a caliber for which a firearm permit has not been issued by the bureau.

(e) Carry a concealed pistol, revolver, or other firearm capable of being concealed upon the person unless one of the following circumstances applies:

(1) The person has been issued a permit to carry a pistol, revolver, or other firearm capable of being concealed upon the person in a concealed manner by a local law enforcement agency pursuant to Section 26150, 26155, 26170, or 26215 of the Penal Code.

(2) The person is employed as a guard or messenger of a common carrier, bank, or other financial institution and he or she carries the weapon while actually employed in and about the shipment, transportation, or delivery of any money, treasure, bullion, bonds, or other thing of value within this state, as specified in subdivision (e) of Section 25630 of the Penal Code.

(3) The person is an honorably retired peace officer authorized to carry a concealed firearm pursuant to subdivision (a) or (I) of Section 25650 of the Penal Code or Article 2 (commencing with Section 25450 of chapter 2 Division 5 of Title 4 of Part 6 of the Penal Code.

(4) The person is a duly appointed peace officer, as defined in Chapter 4.5 (commencing with Section 830) of Title 3 of part 2 of the Penal Code, who is authorized to carry a concealed firearm in the course and scope of his or her employment pursuant to Article 2 (commencing with Section 25450) of Chapter 2 division 5 of Title 4 of part 6 of the Penal Code.

### **Instructor Explanation**

Violations of Business and Professions Code Section 7583.37 may result in disciplinary action, such as fines up to \$1,000. (Business and Professions Code Section 7587.10)

**REQUIREMENTS FOR CARRYING A FIREARM: PROPRIETARY (IN-HOUSE)  
SECURITY GUARD:**



## §7582.2

This chapter does not apply to the following:

(a) A person who does not meet the requirements to be a proprietary private security officer, as defined in Section 7574.01 and is employed exclusively and regularly by any employer who does not provide contract security services for other entities or persons, in connection with the affairs of such employer only and where there exists an employer-employee relationship, provided that such person at no time carries or uses any deadly weapon in the performance of his or her duties. For purposes of this subdivision, "deadly weapon" is defined to include any instrument or weapon of the kind commonly known as a blackjack, slingshot, billy, sandclub, sandbag, metal knuckles, any dirk, dagger, pistol, revolver, or any other firearm, any knife having a blade longer than five inches, any razor with an unguarded blade and any metal pipe or bar used or intended to be used as a club.

(k) A peace officer of this state or a political subdivision thereof while the peace officer is employed by a private employer to engage in off-duty employment in accordance with Section 1126 of the Government Code. However, nothing herein shall exempt such peace officer who either contracts for his or her services or the services of others as a private patrol operator or contracts for his or her services as or is employed as an armed private security officer. For purposes of this subdivision, "armed security officer" means an individual who carries or uses a firearm in the course and scope of that contract or employment.

(l) A retired peace officer of the state or political subdivision thereof when such retired peace officer is employed by a private employer in employment approved by the chief law enforcement officer of the jurisdiction where the employment takes place, provided that the retired officer is in a uniform of a public law enforcement agency, has registered with the bureau on a form approved by the director, and has met any training requirements or their equivalent as established for security personnel under Section 7583.5. [Enumeration and emphasis added.] This officer may not carry a loaded or concealed firearm unless he or she is exempted under the provisions of subdivision (a) of Section 25450 of chapter 2 Division 5 of Title 4 of Part 6 of the Penal Code. 25850 of the Penal Code or has met the requirements set forth in Section 26030 of the Penal Code. However, nothing herein shall exempt such retired peace officer who contracts for his or her services or the services of others as a private patrol operator.

### **Instructor Explanation**

- (1) Guards employed as in-house security guards and who do not carry a firearm are required to possess a proprietary private security officer registration, as defined in sections 7574.01 issued by the bureau. However, any guard employed as an in-house security guard and who carries a baton, must possess a bureau issued guard registration and baton permit. Any in-house security guard who carries a firearm must also possess a bureau issued guard registration and firearm permit.

- (2) Active duty peace officers working off-duty as armed security guards or bodyguards must possess a Bureau issued security guard card and firearm permit.
- (3) Honorably retired peace officers working as armed security guards or armed bodyguards must possess a Bureau guard registration and a Bureau exposed firearm permit. Retired peace officers who: (1) works for a private employer approved by the chief law enforcement officer of that jurisdiction and (2) works in the uniform of that law enforcement agency, are not required to obtain a security guard registration or firearm permit. If these conditions are not met, the retired peace officer must obtain the appropriate bureau permits. A retired peace officer with an endorsement to carry a concealed weapon who works as an armed security guard or armed bodyguard in civilian clothes **MUST** possess a bureau issued guard registration and Bureau exposed firearm permit. A retired peace officer may carry a baton on duty as a security guard only if the he/she possess a Bureau issued baton permit, the baton is exposed and he/she is in a security guard uniform with Bureau approved patches.

Only active duty peace officers who work off-duty as a security guard may carry a concealed baton and are exempt from possessing a baton permit.

### **3. BUREAU STATUTES AND REGULATIONS (California Code of Regulations)** **Administrative Regulations of the Bureau of Security and Investigative Services**

#### REQUIREMENTS FOR CARRYING A FIREARM -- GENERAL

##### **Title 16, CCR 631**

(a) A registered employee shall not carry, use or possess a loaded or unloaded firearm in the performance of his duty, whether or not it is serviceable or operative, unless he has in his possession a firearms qualification card issued to him by the chief. Such card must be shown to any peace officer or bureau representative upon demand.

(b) A registered employee may not carry any replica or other simulated firearm.

##### **Title 16, CCR 631.1**

(a) A private patrol or alarm company operator shall not allow an employee to carry or use a loaded or unloaded firearm, whether or not it is serviceable or operative, unless such employee possesses a firearms qualification card.

(b) A private patrol or alarm company operator may not allow an employee to carry any replica or other simulated firearm.

#### WHO MAY OBTAIN A FIREARM PERMIT

##### **Title 16, CCR 632**

(a) The bureau shall issue a firearms qualification card to an applicant where all the following conditions exist:

(1) The applicant is a licensed private investigator, alarm company qualified manager, private patrol operator who has passed the private patrol operators examination, or registered employee of such a licensee or is employed or compensated by a lawful business or public agency as a security guard or patrol person;

(2) The applicant has filed with the bureau a completed application for a firearms qualification card on a form prescribed by the bureau, dated and signed by the applicant under penalty of perjury that the information in the application is true and correct;

(3) The application is accompanied by:

(A) Payment of the firearms qualification fee prescribed by Section 7588 (I)(1)(2) Business and Professions Code

(B) Proof, satisfactory to the bureau, of successful completion of a course approved by the bureau in the carrying and use of a firearm, including:

1. Proof of successful passage of a written examination prescribed by the bureau. Such examination shall be based on information required to be taught pursuant to Section 635; and,

2. Proof of qualifying on a firearm range with the caliber and type of weapon used by the applicant pursuant to Section 7583.37 (b)(6) and 7585.7(a)(5) of the Business and Professions Code.

(4) The bureau has determined, after investigation, that the carrying and use of a firearm by the applicant in the course of his or her duties presents no apparent threat to the public safety.

(b) The firearms qualification card, when issued, shall be mailed to the applicant at the address which appears on the application. In the event of the loss or destruction of the card the cardholder may apply to the chief for a certified replacement for the card, stating the circumstances surrounding the loss, and pay a \$10.00 certification fee whereupon the chief shall issue a certified replacement for such card.

(c) A firearms qualification card does not authorize the holder thereof to carry a concealed weapon as that term is defined in Penal Code Section 26150.

### **Title 16, CCR 633**

(a) A firearms qualification card expires two year from the date of issuance, if not renewed. A person may renew a firearms qualification card by filing an application within 60 days prior to the card's expiration.

(b) An applicant shall complete and pass the range qualification course of fire requirements by firing 50 rounds for score on two separate occasions, but no sooner than four months apart, within each year prior to the card's expiration.

(e) An applicant shall complete and pass a review training course on the laws and standards regarding use of deadly force and on avoidance of deadly force as provided in this section. Two hours of the review course shall be completed prior

to completing a range qualification course of fire. The training regarding use of deadly force and the avoidance of deadly force may be administered by a Private Patrol Operator or a person designated by the licensee to administer the Powers to Arrest training. The training can also be conducted by a licensed Firearm Training Facility.

#### **Title 16, CCR 637**

Any use of a firearm by a holder of a Firearms Qualification Card which is in violation of law or in knowing violation of the standards for carrying and usage of firearms as taught in the course of training in the carrying and use of firearms may be grounds for suspension or revocation of the holder's Firearms Qualification Card.

#### **4. INSTRUCTOR SAMPLE (See Case Studies in Section C #9)**

### **B. Laws and standards regarding use of deadly force**

#### **1. PENAL CODE SECTIONS**

##### **§197**

Homicide is also justifiable when committed by any person in any of the following cases:

1. When resisting any attempt to murder any person, or to commit a felony, or to do some great bodily injury upon any person; or,
2. When committed in defense of habitation, property, or person, against one who manifestly intends or endeavors, by violence or surprise, to commit a felony, or against one who manifestly intends and endeavors, in a violent, riotous or tumultuous manner, to enter the habitation of another for the purpose of offering violence to any person therein; or,
3. When committed in the lawful defense of such person, or of a wife or husband, parent, child, master, mistress, or servant of such person, when there is reasonable ground to apprehend a design to commit a felony or to do some great bodily injury, and imminent danger of such design being accomplished; but such person, or the person in whose behalf the defense was made, if he was the assailant or engaged in mutual combat, must really and in good faith have endeavored to decline any further struggle before the homicide was committed; or,
4. When necessarily committed in attempting, by lawful ways and means, to apprehend any person for any felony committed, or in lawfully suppressing any riot, or in lawfully keeping and preserving the peace.

##### **§198**

A bare fear of the commission of any of the offenses mentioned in subdivisions 2 and 3 of Section 197, to prevent which homicide may be lawfully committed, is not sufficient to justify it. But the circumstances must be sufficient to excite the fears of a reasonable person, and the party killing must have acted under the influence of such fears alone.

### §198.5

Any person using force intended or likely to cause death or great bodily injury within his or her residence shall be presumed to have held a reasonable fear of imminent peril of death or great injury to self, family, or a member of the household when that force is used against another person, not a member of the family or household, who unlawfully and forcibly enters or has unlawfully and forcibly entered the residence and the person using the force knew or had reason to believe that an unlawful and forcible entry occurred.

As used in this section great bodily injury means a significant or substantial physical injury.

## 2. **GOVERNMENT CODE SECTIONS - Business and Professions Code Sections Statutes of the Bureau of Security and Investigative Services**

### §7583.37

The director [of the Department of Consumer Affairs] may assess fines as enumerated in Article 7 (commencing with Section 7587). Assessment of administrative fines shall be independent of any other action by the bureau or any local, state, or federal governmental agency which may result from a violation of this article. In addition to other prohibited acts under this chapter, no licensee, qualified manager, or registered security guard shall, during the course and scope of licensed activity, do any of the following:

- (a) Carry any inoperable, replica, or other simulated firearm.
- (b) Use a firearm in violation of the law, or in knowing violation of the standards for the carrying and usage of firearms as taught in the course of training in the carrying and use of firearms. Such unlawful or prohibited uses of firearms shall include, but not be limited to, the following:
  - (1) Illegally using, carrying, or possessing a dangerous weapon.
  - (2) Brandishing a weapon.
  - (3) Drawing a weapon without proper cause.
  - (4) Provoking a shooting incident without cause.
  - (5) Carrying or using a firearm while on duty under the influence of alcohol or dangerous drugs.
  - (6) Carrying or using a firearm of a caliber for which a firearm permit has not been issued by the bureau.
- (e) Carry a concealed pistol, revolver, or other firearm capable of being concealed upon the person unless one of the following circumstances applies:
  - (1) The person has been issued a permit to carry a pistol, revolver, or other firearm capable of being concealed upon the person in a concealed manner by a local law enforcement agency pursuant to Section 26150, 26155, 26170, or 26215 of the Penal Code.
  - (2) The person is employed as a guard or messenger of a common carrier, bank, or other financial institution and he or she carries the weapon while actually employed in and about the shipment, transportation, or delivery of any money,

treasure, bullion, bonds, or other thing of value within this state, as specified in subdivision (e) of Section 25630 of the Penal Code.

(3) The person is an honorably retired peace officer authorized to carry a concealed firearm pursuant to subdivision (a) or (I) of Section 25650 of the Penal Code or Article 2 (commencing with Section 25450 of chapter 2 Division 5 of Title 4 of Part 6 of the Penal Code.

(4) The person is a duly appointed peace officer, as defined in Chapter 4.5 (commencing with Section 830) of Title 3 of part 2 of the Penal Code, who is authorized to carry a concealed firearm in the course and scope of his or her employment pursuant to Article 2 (commencing with Section 25450) of Chapter 2 division 5 of Title 4 of part 6 of the Penal Code.

### **Instructor Explanation**

Violations of Business and Professions Code Section 7583.37 may result in disciplinary action, such as fines up to \$1,000. (Business and Professions Code Section 7587.10)

### **3. BUREAU STATUTES AND REGULATIONS (California Code of Regulations)** **Administrative Regulations of the Bureau of Security and Investigative Services**

#### **Title 16, CCR 633**

(a) A firearms qualification card expires two year from the date of issuance, if not renewed. A person may renew a firearms qualification card by filing an application within 60 days prior to the card's expiration.

(b) An applicant shall complete and pass the range qualification course of fire requirements by firing 50 rounds for score on two separate occasions, but no sooner than four months apart, within each year prior to the card's expiration.

(e) An applicant shall complete and pass a review training course on the laws and standards regarding use of deadly force and on avoidance of deadly force as provided in this section. Two hours of the review course shall be completed prior to completing a range qualification course of fire. The training regarding use of deadly force and the avoidance of deadly force may be administered by a Private Patrol Operator or a person designated by the licensee to administer the Powers to Arrest training. The training can also be conducted by a licensed Firearm Training Facility.

### **4. INSTRUCTOR SAMPLE (Instructor discussion)**

Security guards should always remember that deadly force should be used only as a last resort when all other means of defense, including evading the situation and the most important factor of all: No innocent life is in danger from the actions of the security guard

### **C. Avoidance of deadly force – The de-escalation of force**

The principles of de-escalation of force and avoidance of deadly force are discussed below. They are also incorporated into the case studies.

Every person in possession of an exposed weapon permit issued by the Bureau has a legal and moral obligation to avoid using deadly or lethal force unless there is an imminent danger to life. Further, a person with an exposed weapon permit has an obligation to do everything possible to de-escalate conflict situations that could lead to dangerous situations.

The armed security guard, alarm agent, private investigator, private patrol operator, or qualified manager, who has been issued a firearm permit, holds a position of special trust and responsibility. An armed security guard has been entrusted to carry a deadly weapon.

That guard also has the responsibility to use that weapon only if there is an imminent threat to life, only if there is no other option to the use of deadly force and only if the person has taken all precautions to avoid the use of deadly force.

An armed security guard has an obligation to establish and maintain competency in the use of the weapon carried on duty. Competency also includes being competent in the techniques that avoid or reduce the possible use of deadly force.

Competency in techniques that avoid or reduce conflict includes an awareness of how your behavior may affect another person in a conflict situation. Awareness of the affects of your behavior may improve your competency in handling conflict situations. Your behavior may contribute to an increase or a decrease in the level of conflict in such a situation. Your personal behavior involves the totality of your conduct, including the words you use, the tone of your voice, your facial expressions, body stance and body movements. Threatening, aggressive, or offensive behavior may aggravate the situation and make controlling the situation more difficult. At worst, such behavior may increase the level of conflict and result in a use of force that perhaps could have been avoided. On the other hand, non-aggressive behavior, such as speaking politely in a calm voice, not standing in a threatening manner and not placing your hand on the weapon, may contribute to not escalating the situation.

You are responsible for your behavior. In a shooting, your behavior may be thoroughly reviewed. If your behavior is shown to have contributed to the escalation of conflict that resulted in a shooting, you may be held totally or partially responsible.

Participants in an actual shooting often have very strong short-term and long-term physical, emotional, and psychological reactions. These are normal reactions.

One normal reaction to a perceived threat is called the Fight or Flight reaction. The body and mind naturally responds to a threat by preparing to fight (for example, shooting) or for flight (for example, withdrawing). Some typical short-term physical reactions to a fight or flight situation are a greatly increased heart rate and breathing rate, tunnel vision, tremors

(shaking of hands), vomiting, and the loss of control of body functions. Because it is extremely unlikely that you will be wearing ear protection in a shooting, the loud explosive sound of the shot(s) may make your ears ring, perhaps for weeks. You may even have permanent hearing loss. Some typical emotional and psychological reactions to a shooting are nightmares, anxiety, fatigue, and loss of appetite, concentration, memory and sexual interest. These reactions may be short-term or long-term and are common during and after a shooting.

These reactions are not often discussed nor well known to the general public. These reactions are seldom portrayed in movies, on TV, or discussed in the press or media. But they are well known to combat veterans, shooting survivors, and health professionals. Just think about how emotionally and physically upset you may have been in a recent heated argument or conflict. Now think about how much stronger your reaction may be if your life is threatened, such as with a gun.

The purpose of this section is to provide the student with various options to consider when in a threatening situation. Keep in mind that in a real shooting, events may move very quickly and all the involved parties will most likely be experiencing the fight or flight response to some degree.

In a shooting, time may be greatly distorted. You will not have the luxury of being in a class and coolly thinking about the options and what is the best thing to do. The greater the perceived threat, the greater the fight or flight response will be.

After the shooting, there may be a police investigation and possible media interest. You may also be subject to criminal prosecution and/or a civil lawsuit because of an alleged violation of law or improper procedure. The facts and circumstances after the shooting will be investigated to determine if the shooting was justified, if your guard card and firearm permit were valid and if you complied with all appropriate procedures and requirements.

The issues below are to be thoroughly discussed in order to promote critical thought and review. Instructors and students are to then consider these issues when reviewing the cases to determine the appropriate case response.

### **1. Avoid, Observe and Report:**

A guard following the principles of Avoid Observe and Report would avoid the conflict and observe the suspect(s) in order to factually report the situation to superiors and/or law enforcement as soon as possible. The guard would not confront and may literally retreat from the suspect or the conflict situation. The guard would continue to maintain a visual presence by allowing the suspect and other persons to see the guard.

### **2. Cover and Concealment:**

A guard engaging in cover and concealment would seek protective cover, such as behind a barricade or wall, remain hidden from the view of the suspect(s) and report



the situation by phone or radio if possible. If safe, the guard would observe the situation in order to factually report the situation. However, the primary objective is to maintain personal safety and the safety of others. The guard would not confront the suspect(s).

### **3. Escalation of Force:**

The escalation of force is the increase in the amount of force used in a conflict situation. Ideally, the situation would allow for the guard to do a step-by-step increase in the use of force. However, in the real world, it is not always possible to respond in this ideal manner. Generally, however, it is possible and appropriate to gradually increase the level of force but stop short of using a firearm.

### **4. Self Control:**

The most important person to control in a conflict situation is yourself. You may truly have no control over what anyone else does in a conflict situation.

### **5. Visual presence:**

This level is often called a visual deterrence. This means a guard simply allows him/herself to be clearly seen. The fact that a guard can be clearly seen by anyone may in itself inhibit a potential conflict situation. For example, if a person is considering committing a crime or engaging in hostile behavior then sees a guard standing or patrolling nearby, that person may NOT commit the crime or engage in hostile behavior. Thus a potential conflict situation, and the risk of escalation in the use of force by the guard, may have been avoided because the guard maintained a visual presence. A guard can easily maintain a visual presence in a relaxed, alert and non-threatening manner. This in turn may reduce the possibility of force.

### **6. Verbal Communication:**

Engaging in a simple non-threatening, non-hostile verbal communication is often not thought of as a possible show of force, but it can be. There are many other factors involved in effective verbal communication than just talking, especially in tense conflict situations. When engaging the subject in verbal communications, be aware of how the following factors can inhibit or promote conflict:

#### **a. Your physical stance:**

Maintain a non-threatening stance and appearance. For example, stand straight and relaxed with your hands at your side. **UNLESS JUSTIFIED, DO NOT** stand in a threatening ready position, such as with your hand on your firearm or your

baton. The more calm and non-threatening your total physical stance and gestures are, the more likely that you will appear non-threatening. This non-threatening appearance may contribute to more effective communications in a delicate situation.

b. Physical Closeness:

Maintain an appropriate distance from the subject. This not only may contribute to your safety but may also cause you to appear less threatening to the other person. What an appropriate distance is depends on the factual situation. An appropriate distance may be one foot in a loud, crowded nightclub, 10 feet during a crowded demonstration or five feet in a parking lot. In a conflict situation, it is generally best to never touch anyone and to always maintain an appropriate and safe distance, even if you must take a step back from the suspect while talking and listening to the subject.

c. Tone of voice:

Speak in a calm and respectful tone. Do not speak in a loud, cursing manner. The more politely someone speaks at you, the more likely you are to be polite to that person. Be polite and calm in conflict situations, especially if you are giving a firm directive. This may be hard to do when the subject is hollering and cussing at you or others. While this may be hard to do, you often can keep a situation from escalating and control the situation more effectively. For example, you may be far less threatening by saying: Please, sir, or, Excuse me, miss.

## **7. Physical Control Levels:**

The physical control levels in escalating order are: physical contact, use of pepper spray, use of baton, and use of firearm. Remember that all of these levels may be used only for justifiable defensive purposes. A guard who engages in physical control with a subject must be able to establish that it was reasonable and justified.

a. Physical Contact:

There are many factors for a guard to consider prior to initiating physical contact in any conflict situation. The most important may be does the situation justify the use of physical force? Is there a real and immediate threat to the physical safety of the guard or another person? If the answer to these questions is “No”, physical contact may not be justified. If physical force is not justified, an appropriate response may be for the guard to withdraw and contact the supervisor or the police. A physical withdrawal by the guard may be required. If physical contact is justified and required, then there are many other factors to consider, including: the

age and size of the guard relative to the subject; the guard's physical condition and training in physical control techniques; the potential number of subjects the guard may confront; the availability of immediate assistance; the possibility that the subject may be armed with an unseen weapon, such as a knife, or under the influence of drugs or alcohol; the medical, mental and psychological state of the subject; the possibility of being overpowered resulting in an increase of force and serious injury; and company policy regarding the use of physical force.

Unless physical force is justified and required by an immediate threat, such as being physically attacked, withdrawing from the conflict situation, avoiding physical contact with the suspect, and then notifying the police to respond to the situation, may be the only proper and appropriate action for the guard to take.

b. Using Pepper Spray:

Pepper spray may only be used as a defensive response. Therefore, prior to using pepper spray, the situation must justify the use of pepper spray as a defensive response. There are also other factors to consider; such as: Is there a danger from the pepper spray to anyone nearby, such as an elderly person, infant or obviously sick person? Will using pepper spray increase the level of conflict? For example, if a suspect has a knife, will using pepper spray be wise even if it is justified? Should the guard retreat, avoid the conflict, not use pepper spray and then notify the police to respond to the situation?

c. Using a Baton:

A baton may be used only for defensive purposes. The situation must justify the use of a baton as a defensive response. There are many factors that the guard should consider prior to using a baton which are covered in the baton-training course. In terms of de-escalation of force, would the use of the baton only increase the conflict and make the situation worse? For example, if the suspect were drunk, uncooperative and refusing to leave, would use of a baton be justified? Should the guard retreat, not use the baton, contact the police and wait for them to respond to the situation?

d. Using a Firearm:

A firearm **MUST** be used for only defensive purposes. It is the highest level of force. The situation must justify the use of deadly force. That is, there **MUST** be an imminent and immediate danger to life. A shooting carries a high degree of risk for all involved parties and for innocent bystanders as well. The shooting will result in the guard and the company being thoroughly investigated by the local police and the Bureau. If the shooting is not justified or if policies or procedures were not followed, the guard, and the company, may be subject to criminal prosecution, civil action or both.

## 8. Principles of de-escalation:

In de-escalation, the guard takes active steps to remove, withdraw, retreat or distance himself/herself from the persons involved in the conflict for the purpose of avoiding and diffusing the conflict. This may range from not stepping forward in response to a challenge, to physically retreating for the purpose of avoiding conflict, to taking cover to prepare to only observe and report. A good general rule to follow is this: If there is not a justification to use force, then engage in de-escalation. Do not engage in behaviors that escalate the conflict and result in the use of any force. This may mean NOT physically or verbally confronting nor pursuing a subject, or stepping back and retreating from the conflict, or withdrawing, taking cover and only preparing to notify and report to the police.

For example, suppose that while on duty you observe an armed robbery occurring at a store across the street from the property you are guarding. There is no justification for you to confront the robbers or initiate the use of force. The person and property you are assigned to protect is not under any immediate threat, neither your client's business nor property is being robbed, and you are not trained to intervene in an armed robbery in progress across the street. The only appropriate response is for you to take cover, stay on post, notify the police, observe and prepare to report.

In discussing the case studies below, consider each of the following questions in your discussion:

- (1) Does a clear and present danger exist to justify a shooting?
- (2) Should the guard escalate or de-escalate, such as shoot, pursue, retreat, cover and conceal, avoid contact, and/or observe and report and wait for local law enforcement to respond to the situation?

## 9. Case Studies:

**INSTRUCTOR EXPLANATION:** Instructors are to thoroughly review and actively involve each student in the discussion of the case studies. The discussions are to focus on assessing the total situation and consider an appropriate response to each case. An appropriate response to the case may be one of the following: the use of a firearm; use a lesser type of force, such as a baton; engage in de-escalating behaviors to reduce the conflict and avoid the use force, such as physically withdrawing from the conflict; or engage in cover and concealment and prepare to only observe and report.

\*\*\*

### Case Study #1

You are patrolling a large parking lot of a retail store when you are told that there is an armed robbery in progress. You turn towards the entrance of the store and see a man with a gun in his hand run out the front door, turn and run away from you and down the public street.

### Discussion

Should you pursue the man? Are you or anyone else in imminent danger? Should you check on the people in the store?

\*\*\*

### Case Study #2

You are working in a shopping center. You are told by a citizen that there is a person acting strangely in an outdoor parking lot. The citizen believes that the person is drunk or possibly under the influence of drugs. You arrive at the scene where a crowd has gathered around a large male approximately 16 to 18 years old in an incoherent and agitated state. You identify yourself and the subject becomes even more agitated. The subject takes a large knife from his pocket, extends the blade, and begins to advance toward you as the crowd moves out of his way.

### Discussion

What body posture and tone of voice should you use when addressing the man? Should you draw your firearm? Could the use of baton or pepper spray work in this situation? Should you call for back-up? When should you notify the police?

\*\*\*

### Case Study #3

You have been told that a burglary has occurred earlier in the evening at a warehouse you are guarding. The suspects were observed leaving the scene in a blue 1995 Dodge.

Later that night, while patrolling the parking grounds in a well-marked security vehicle, you observe a similar vehicle traveling through the parking lot at a slow speed with the headlights off. You see a flash come from the driver's side of the suspects' vehicle and almost simultaneously the front windshield of your patrol car shatters. The suspect vehicle then accelerates through the parking lot at a high rate of speed and heads for the exit.

### Discussion

Should you pursue the vehicle? Should you notify the police? Did you observe any details of the vehicle or its occupants that might help the police?

\*\*\*

#### Case Study #4

You are on duty patrolling near the exit doors of a large retail store. Suddenly, you hear a shot and see that someone has fallen down at a check stand. The shooter then runs out the door to an open area where he wildly shoots twice at people walking about and who are in cars in the parking lot. He does not see nor shoot at you as he then runs through the parking lot towards the street.

#### Discussion

Are you in immediate danger? Is anyone else in immediate danger? Do you draw your weapon? Do you shoot? Do you not shoot? Are others in your potential line of fire? Do you pursue? Do you consider his size and age? Do you call for emergency medical assistance? Do you notify the police and prepare to only observe and report?

\*\*\*

#### Case Study #5

You are on foot patrol at a used car lot at night. While patrolling a dark corner of the lot you observe a man forcing entry into a car. You cannot determine if the man is armed. You are standing approximately 15 feet behind him and order him to "hold it right there." He spins around and throws an antenna at you which misses. He then begins to climb over the fence.

#### Discussion

Should you draw your gun and order the man to stop? Should you grab the man in an attempt to hold him for police? Should you let the man go and tell the police what you observed?

\*\*\*

#### Case Study #6

You are on duty at a nightclub where an agitated customer is behaving in a loud and threatening manner. Your client, the owner, directs you to tell the customer to leave. You are aware that in the past when this customer was told to leave the premise, he attacked the owner with a broken bottle. You approach him cautiously through a crowd of several people and politely but firmly tell him to leave. Suddenly, you feel your baton being pulled on by someone in the crowd who you can not identify. You maintain control and possession of your baton but as you do so the agitated customer

pulls out a knife and begins to approach you in a very threatening and hostile manner. The crowd quickly backs away.

### Discussion

Should you prepare to use your baton? Should you draw and prepare to use your gun? Are other people nearby threatened? Should you step back and withdraw?

Given your awareness of his previous violent history, should you have approached him alone, if at all? Should you have first called the police?

\*\*\*

### Case Study #7

You are on guard duty during normal business hours in a bank. You see a man with a gun aimed at the teller at a teller window. You are standing next to a pillar in the middle of the room. There are people around you, behind you, on either side of you, and behind the teller. The suspect turns, sees you and fires at you while running out of the bank.

### Discussion

Should you first find cover? Should you shoot in return? Why or why not? Is there imminent danger to you and others in the area? If the man shoots at you again, should you shoot in return?

\*\*\*

### Case Study #8

You are the only security guard working at a bank. You have just gone to the lunchroom for your break when a bank employee informs you that an armed robbery is in progress.

### Discussion

Is the best course of action to call the police immediately from the lunchroom? Should you avoid entering the scene while the robbery is in progress? What course of action would maximize your safety and the safety of others? Should you take cover near the bank exit that would be the likely escape route so you can observe and report from a covered and concealed position?

\*\*\*

### Case Study #9

You are a security guard on duty patrolling the parking lot of a popular restaurant. A male with a gun approaches you from behind and demands that you give him your gun. As you are removing it from your holster, the suspect shoots at you once, misses and run towards the street. People start screaming and running.

### Discussion

Once the suspect begins to run, should you shoot at him? Since the assailant is fleeing, should you pursue? What risk do you take if you do shoot? Is anyone in imminent danger? Should you concentrate on observing and preparing to report?

\*\*\*

### Case Study #10

You are a security guard on duty with your partner patrolling the parking lot of a popular restaurant. A male with a gun approaches you and your partner from behind and demands that you and your partner give him your guns. As you are removing the gun from your holster, the suspect shoots your partner in the thigh once then runs towards the street as your partner falls down moaning. People start screaming and running.

### Discussion

Should you shoot at the suspect who is running away? What risk(s) do you take if you do shoot? Is anyone in imminent danger? Should you pursue the suspect? Should you call for medical and police assistance? Should you concentrate on observing and preparing to report?

\*\*\*

### Case Study #11

While working at a manufacturing plant, you receive a call informing you that there may be a prowler in the back of the plant. As you approach the area where the suspect has been observed, you see a figure apparently crouching behind some bushes. Suddenly the figure starts to run toward the perimeter fence. You call to the person to halt but he continues to run.

### Discussion

Should you shoot? Is the person a suspect or a possible innocent victim? Should you pursue? Should you observe and report? What is the safest course of action to take?

\*\*\*



### Case Study #12

There have been a series of burglaries committed by two males in their twenties at a large apartment complex where you work. While patrolling, you observe a young male run into a darkened apartment building. You pursue and as you are walking down a deserted and darkened hallway, you observe someone at the end of the hall, but you cannot see who it is. You then see something shining in his hand but you can not identify what it is.

### Discussion

Should you assume it is a firearm, retreat and take cover? Should you draw your weapon and prepare to shoot in self-defense? Should you initiate verbal contact? Are you justified to shoot immediately? Should you assume the person is a burglar? Should you ask the person to stop forward? Should you withdraw and call the local police? Could it be a tenant?

\*\*\*

### Case Study #13

You are working the night shift at a manufacturing plant doing a routine perimeter check when you find an open back window leading to the administrative offices. You look through the window and observe a man crouched by the safe with the safe door open. You call to the man and he breaks into a run for the front door.

### Discussion

Should you shoot? Are you or anyone else in danger by his running away? Can you determine if the suspect is armed? Is this important? Should you pursue or take up a position to observe and report? Should you call for assistance? Should you call the local police?

\*\*\*

### Case Study #14

While on the night shift at a lumber mill, you hear shooting in the hills behind the mill. You are cautiously checking the mill perimeter area, you hear a shot and a bullet hits the wall near you. You turn to look to the hills and, due to the bright mill lights and full moon, see a man taking aim in your general direction with a rifle.

### Discussion

Should you immediately take the best cover possible, even if it is only to drop to the ground? Can you determine that the suspect has seen you or is he just shooting

randomly in the hills? Can you protect yourself with cover and call law enforcement?  
How do you consider the range and accuracy between a pistol and a rifle?

\*\*\*

### Case Study #15

You and a fellow security guard are on duty at a waterfront warehouse. You notice a door forced open, a car parked nearby and you conclude a burglary may be in progress. You have notified the local police department. As you begin to enter the warehouse to observe, you hear police cars pulling into the area.

### Discussion

Should you enter the building now that the police have arrived? Should you inform them of the facts you have observed, stand out of the way, and allow them to take further action?

\*\*\*

### Case Study #16

You are on duty in the evening at a grocery store. You are in the middle of the store where several customers are shopping. Suddenly you observe a man at the counter and the clerk taking money from the register and putting it into a paper bag. You see another man by the entrance of the store with his hands in his pockets.

### Discussion

Should you assume that the man at the front door is a lookout? That he has a weapon? That any sudden movement on your part may provoke the robbers to use weapons? Should you take cover? Should you draw and prepare to use your weapon since they may use a weapon? Are people potentially in a line of fire? Should you concentrate on your safety and in observing a detailed description of the robbers so you can observe and report? Should you shoot if you observe weapons but there is no shooting? Would seeing weapons drawn constitute an immediate life-threatening situation and justify shooting?

\*\*\*

### Case Study #17

You are on duty and in the kitchen of the restaurant. A waitress informs you that a male is threatening a group of people in the restaurant.

### Discussion

Should you ask the waitress to call the police immediately? Should you ask the waitress describe the situation fully? Is the man armed? Could you manage to view the incident without being seen? Could your sudden presence cause a more serious situation? Has the man attacked or hurt anyone? Is anyone in immediate danger?

\*\*\*

### Case Study #18

As you arrive to begin duty as a guard at the bank, you observe two men run out of the bank, down the street and towards a parked car with the motor running and a driver at the wheel.

### Discussion

Are the men armed? Can you determine if a crime has been committed? Should you pursue? Is any one in immediate danger? Should you seek cover and observe from a covered position? Should you get a description and license number of the car? Should you call the police and continue to observe until receiving further instructions?

\*\*\*

### Case Study #19

You are on routine patrol at 0300 hours approaching a large theater complex that is closed. You observe a man about 75 feet in front of you suddenly come out of a dark alley between a building and the theater. He turns onto the sidewalk and walks quickly away from you. You then notice that a door at the side of the theater is open. You call to the man to stop. As he turns toward you, you observe something shiny in his hand reflected by the street light.

### Discussion

Do you have a reason to believe a crime is being committed other than the fact that the theater utility door is open at an odd hour? Should you take cover in the event he is armed? Should you approach him to investigate further? Should you draw your weapon? Should you withdraw? Should you observe and report? Should you call the police? If he runs, should you pursue?

\*\*\*

### Case Study #20

You are assigned a patrol car to supervise other guards. A guard at warehouse reports that he thinks someone has broken into the warehouse. As you drive up you hear a shot and at the same time you observe a man run from the back of the building with a gun in his hand. You call to the man to STOP but he keeps running towards a fence that runs along the backside of the building.

## Discussion

Should you pursue? Should you immediately call police to inform them of the situation? Should you call for immediate medical assistance since someone may be shot? Should you shoot?

### **D. Shooting Incidents (Civil and Criminal Liability)**

#### **1. Criminal Liability**

Criminal liability is the potential for a criminal penalty one incurs for committing a criminal act. This liability may include an arrest and booking; a court trial; a conviction; and sentencing. A sentence may include payment of a fine, a prison sentence, probation or community service, and monetary restitution. An entry is also made on the subject's criminal history record, maintained by the Department of Justice.

The parties in a criminal process include the defendant (the accused) and the prosecution (the People of the State of California).

For example, suppose a guard fatally shoots a fleeing suspect in the back. The guard may be subject to criminal prosecution for the shooting. The guard may be charged with a crime (such as manslaughter), arrested, booked, and prosecuted in a criminal court, convicted, and sentenced to prison.

#### **2. Civil Liability**

Civil liability is the potential non-criminal legal consequences one incurs from the commission or omission of an act. A civil liability is separate from the criminal process and can not result in a person being arrested or sentenced to jail or prison. Civil judgement may result in a civil trial and one party being ordered by the civil court to pay money to another party for "damages." The process generally involves one party filing a civil suit against another party in a civil court. The parties to a civil process are the "Plaintiff or Petitioner" and the "Respondent or defendant".

For example, suppose a guard fatally shoots a fleeing suspect in the back. The guard, his employer, and any other person party to the shooting, such as a supervisor, may be subjected to a civil suit for the shooting and wrongful death of the deceased. This means, for example, that the civil trial may find that the guard has deprived the family of the love, comfort, and financial support of the deceased. If the family members win the civil law suit, the guard, employer and other parties responsible for the deadly shooting may be required to pay monetary damages to the family of the deceased. In the example given above, a guard shot and killed a fleeing suspect in the back. The guard may be subject to criminal prosecution and a prison sentence AND subject to a lawsuit resulting in the guard being ordered to pay money to the suspect's survivors.

#### **E. Effects of firearm use (Instructor discussion)**

Instructors are to familiarize and instruct students on how and why bullets travel and what implications this has on the use of deadly force.

### **III. FIREARM NOMENCLATURE AND MAINTENANCE**

#### **A. The revolver and semi automatic, ammunition, parts and nomenclature.**

##### **1. Picture of revolver and semi-automatic with parts identified.**

- a. A picture of a revolver with parts and identified is located on page 64.  
(See Illustration A)
- b. A picture of a semi-automatic with parts and identified is located on page 65  
(See Illustration B)

##### **Instructor Explanation**

Instructors should inform students that while guns vary according to manufacturer and model, the illustrations represent a basic overview that can be applied to all guns.

##### **2. Revolver and semi-automatic, parts and description. (Instructor Discussion)**

###### **I. Revolver**

- a. Frame
- b. Cylinder
- c. Trigger guard
- d. Trigger
- e. Stock or grip
- f. Barrel
- g. Ejector rod
- h. Front sight
- i. Top strap
- j. Rear sight
- k. Cylinder bolt notch
- l. Hammer
- m. Backstrap
- n. Cylinder release

###### **II. Semi-automatic**

- a. Front sight
- b. Muzzle

- c. Frame
- d. Slide stop
- e. Trigger guard
- f. Trigger
- g. Magazine catch/release
- h. Magazine
- i. Stock or grip
- j. Hammer
- k. Rear site
- l. Slide
- m. Barrel
- n. Safety catch/Decocking mechanism
- o. Breakdown pin
- p. Tang

**3. Picture of ammunition with parts identified.**

- a. See Illustration C on Page 66

**4. Ammunition parts and description. (Instructor Discussion)**

Ammunition parts description, altogether known as a cartridge.

- a. Cartridge case
- b. Bullet
- c. Powder
- d. Primer
- e. Explain rifling and identifiable characteristics of fired bullet.

ILLUSTRATION "A"

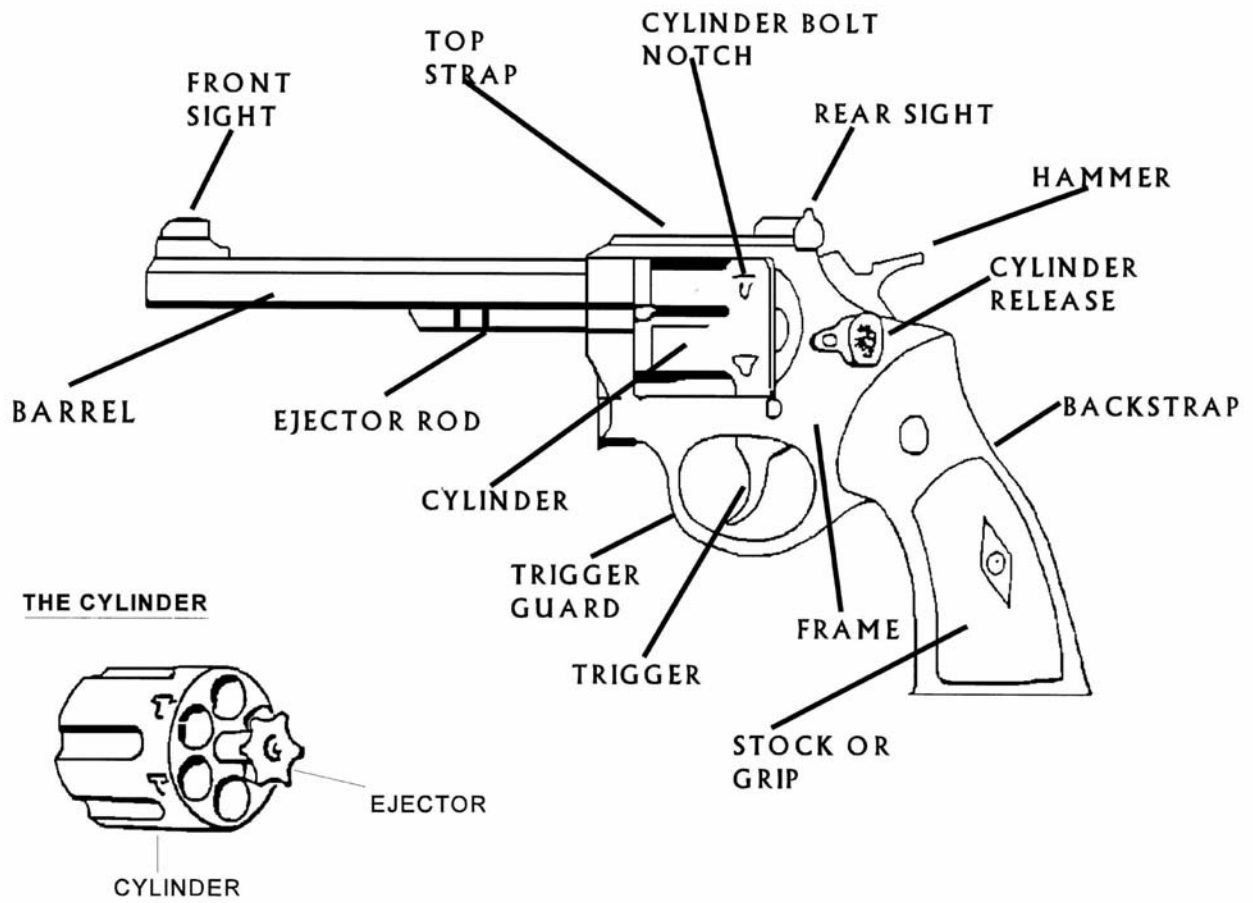

ILLUSTRATION "B"

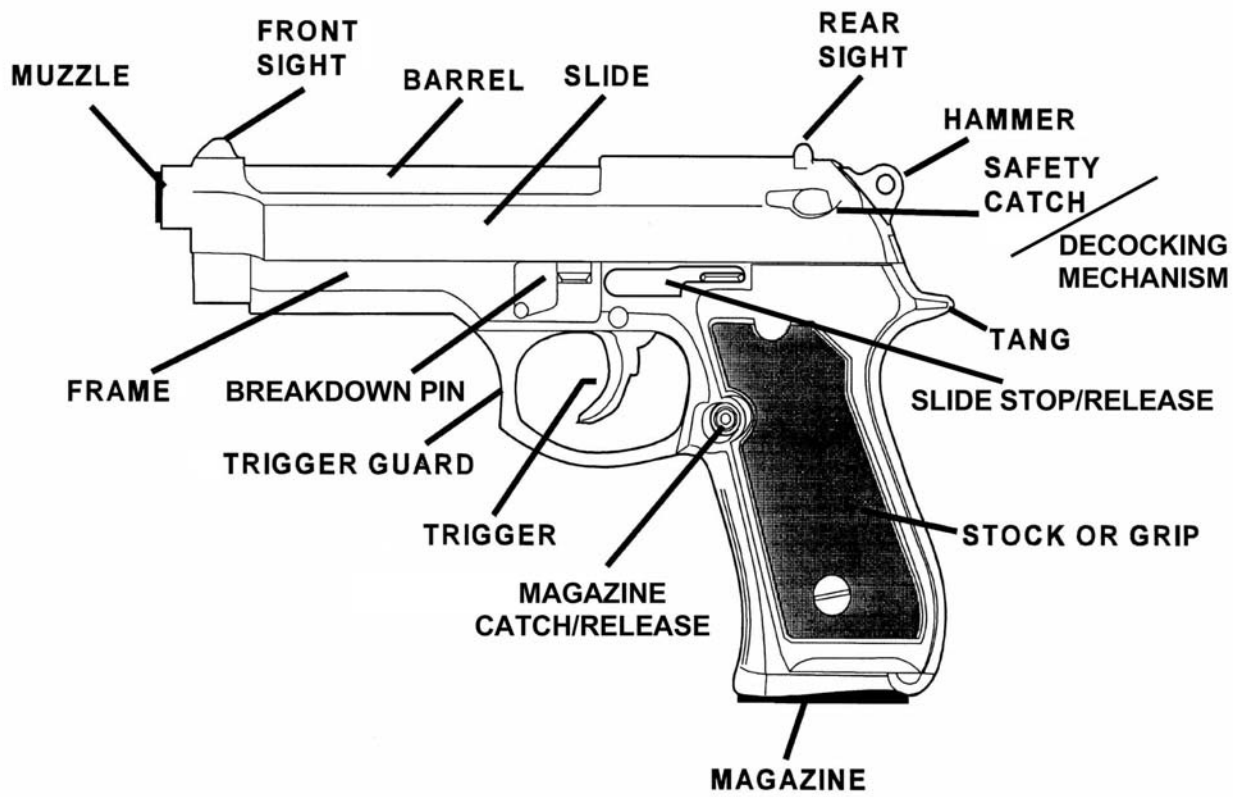
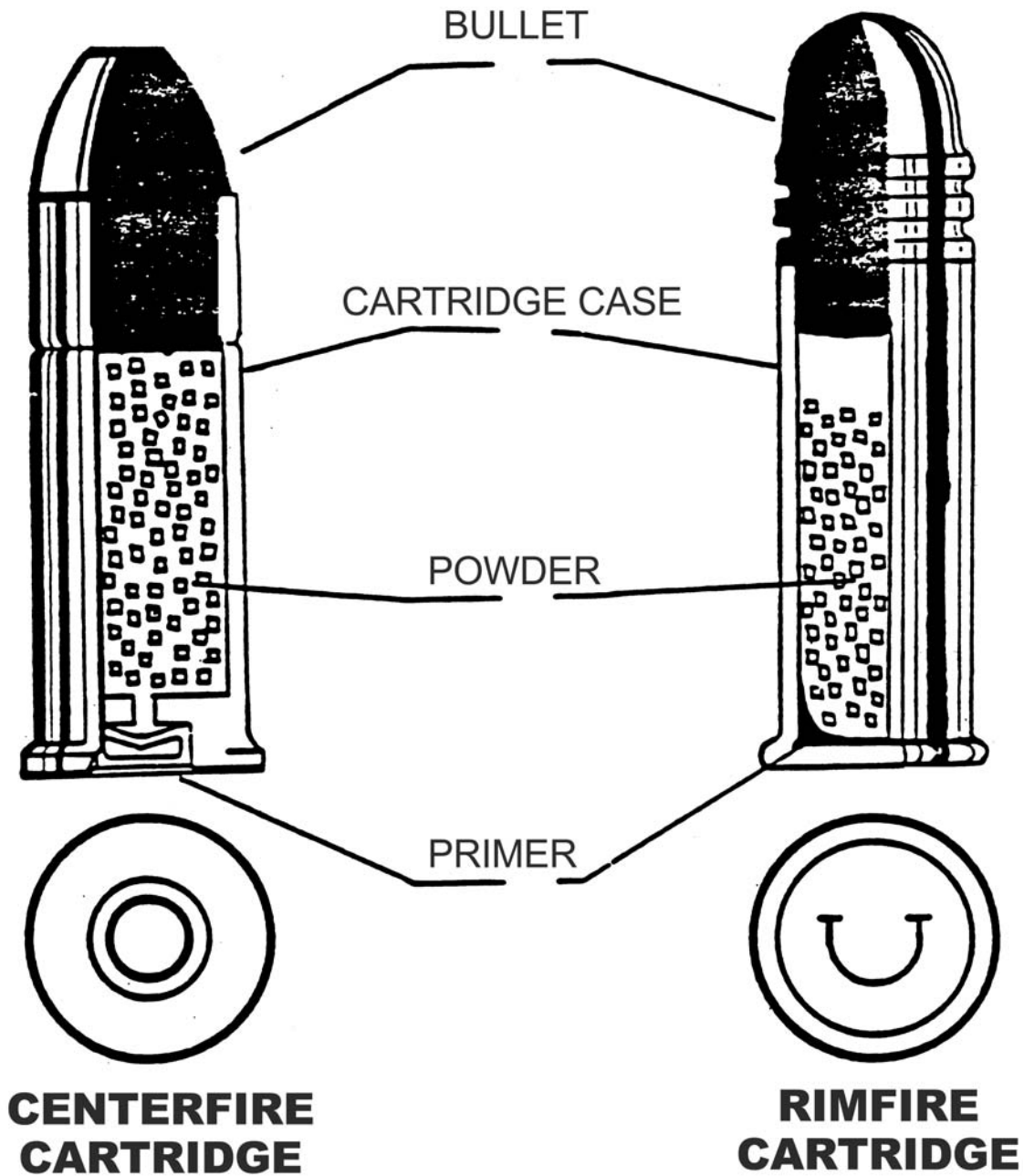

ILLUSTRATION "C"





**B. Firearm Safety, general. (Instructor Directions)**

**1. General Safety Rules**

Students are to be instructed to observe all standard safety rules pertaining to firearms. This includes the following:

- a. To treat all firearms as though they are loaded.
- b. To never point a firearm at anyone unless there is a legal justification to shoot.
- c. That semi-automatics eject hot casings, sometimes at high velocity, creating a hazard and distraction. (Discussion)

**2. Specific Safety Rules. (Range Safety Rules - demonstrate and explain as appropriate)**

Inform students that on the range, strict discipline must be maintained. Carelessness will not be tolerated. Point out the following:

- a. Students are to pay strict attention to the range officer who will provide instruction.
- b. Never anticipate a command. Wait for a command to be announced.
- c. All firearm training must be properly and adequately supervised.
- d. Upon picking up a firearm, render it safe:
  - (1) Revolver - Open cylinder and check chambers.
  - (2) Semi-automatic - remove magazine, lock slide to rear and check chamber.
- e. Never give a firearm to, or take a firearm from, anyone unless the action is open.
- f. Before loading a firearm, be sure there are no obstructions in the barrel.
- g. Load only after position is taken at the firing line and the command to load has been given.
- h. Unload when and as instructed.
- i. Keep the firearm pointed down range at all times, when not holstered.
- j. Keep the finger away from the trigger except when ready to fire.
- k. No talking is allowed on the firing line except for instructions to the shooters.
- l. Never permit the muzzle of a firearm to touch the ground.
- m. Never let the hammer down on a live cartridge. Raise free hand to signal instructor.
- n. In case of a misfire, keep the barrel pointed down range and raise free hand to signal instructor.
- o. Never fire a succeeding shot after a malfunction. Keep barrel pointed down range and raise free hand to signal instructor.
- p. Never carry a loaded firearm onto the range or leave the firing line without first unloading the firearm.
- q. Never walk in front of the firing line until it has been cleared and the command is given to go forward.
- r. Never dry fire on the range except under supervision of the instructor.
- s. No one is to be allowed on the firing line except those firing and instructors.
- t. When holstering a firearm, keep your thumb pressed against the hammer.

**REMEMBER:** Students must carefully follow all directions in order to help prevent accidents.

### **3. Safety at Home and Off Duty. (Possible Criminal Prosecution)**

In the home, a firearm must be kept out of the reach of children and inaccessible to curious teenagers. A locked cabinet or drawer provides an acceptable storage place. The higher the storage area, the less likely it is that children will attempt to retrieve it.

Should a child gain access to your weapon at home resulting in injury, and you did not take sufficient precautions to secure the weapon, you are subject to criminal prosecution. (PC 2500 – 25225)

A firearm should always be kept in the same location when not in use, assuring that adult family members will be able to retrieve it, if needed. Discuss the following methods of storage:

- a. Padlock (shank coated with rubber, padded) through the frame of the firearm.
- b. Trigger lock.
- c. Lockable firearm container.

Ammunition must be kept in a safe location away from the handgun. Store the ammunition in a locked and secure metal container in a cool, dry place to prevent deterioration.

### **4. Transporting the Weapon to the Range**

Firearms are to be transported to the range unloaded in a locked gun container. (P.C. 25540 & 25505)

At the range, students must leave their firearms in the gun case until the instructor gives further instruction.

### **5. Carrying the Weapon on Duty. (Transportation of Weapon)**

In a safe area, inspect the firearm and ammunition for defects before going on duty. When on duty, the firearm must remain properly holstered at all times. Do not neutralize the safety features of the holster. Do not remove the firearm to show, compare, or demonstrate the weapon or to threaten with it.

Note: PC 26030 (a)(10) allows a guard with a firearm permit and in uniform to carry a loaded firearm while in direct route to and from their residence and place of employment or to employer-required range training. A guard may not make any stops while in route.

### **6. Suggested eye and ear protective equipment.**

If the range instructor does not provide ear and eye protection or if there is a rental

charge, students should be informed prior to range instruction.

### **I. Ear Protection**

- a. Hearing loss due to firearms discharge can be permanent and cumulative.
- b. To prevent hearing loss, students should wear ear protection when shooting.
- c. Ear protection is designed to reduce the effect of ear damaging sound waves produced by gunshots. It will not eliminate all noise.
- d. Students must be able to clearly hear all range commands.
- e. Hearing impaired students must be provided with effective alternative method of communications.

### **II. Eye Protection**

- a. Firearm and ammunition systems work at very high pressures, creating hot, high velocity gases and fast moving particles.
- b. When there is a failure in the system, the gas and propelled particles of primer, case, powder or gun, can cause severe injury.
- c. Prevent eye injury by wearing eye protection when shooting.
- d. Wear only protective lenses or prescription glasses with SAFETY lenses.

## **7. Inspection, Cleaning and Maintenance**

### **a. General Information**

When properly maintained, a firearm can be expected to function properly. The firearm should be inspected periodically to determine whether or not it is in good working condition. It should be inspected before and after shooting and should be cleaned after shooting. During cleaning, the firearm should be thoroughly inspected.

### **b. Inspection**

#### **1. Revolver**

##### **a. Screws:**

Check the tightness of the screws on the side plate of the handgun, the screw holding the stocks, and all other visible screws.

##### **b. Ejector Rod:**

Check the area between the ejector rod and cylinder well into which it fits to determine if it is clean and if the ejector drops neatly into the recess.

Examine the ejector rod to determine if it is bent or marred in anyway. Check it for looseness, and tighten if necessary.

c. Firing Pin (those with exposed firing pins):

Check the firing pin for looseness and penetration.

d. Cylinder Alignment:

Check for excessive looseness by cocking the hammer. If there is excessive play, the weapon should be inspected by a competent gunsmith.

e. Exterior:

The handgun may develop rust spots from perspiration or climate. Check for cracks in exterior.

f. Hammer:

Check to see that it cocks, jar the butt to see if hammer falls on its own.

2. **Semi-Automatic**

a. Barrel:

Check for excessive looseness with slide forward.

b. Frame:

With weapon field stripped, examine slide rails for cracks, burrs or excessive wear.

c. Slide:

With weapon field stripped, examine all contact surfaces for cracks, burrs or excessive wear.

d. Magazine/Catch Release:

- (1) Check to see that magazine drops freely when magazine release is depressed.
- (2) Examine for dents, cracks and burrs.
- (3) Check for smooth travel of follower.
- (4) Check to see if slide locks back with empty magazine.

e. Magazine Well:

Examine for cleanliness. Determine if magazine locks in firmly.

c. Cleaning

Under normal conditions, the firearm should be cleaned when it comes in contact with moisture or any possible obstruction such as dirt and dust.

The build-up of powder residue, shaved lead, and other debris that occur during shooting can penetrate the action of the firearm and eventually cause mechanical problems.

Firearms must be properly lubricated.

Firearms should be cleaned after each shooting.

d. Cleaning Kit

An acceptable gun cleaning kit will include, but is not limited, to:

- (1) A can of lubricating oil. (**NOTE:** Never use household oil, as it will collect dust and other particles.)
- (2) A can of solvent.
- (3) A bore brush.
- (4) A bore patch holder.
- (5) Bore patches.
- (6) A toothbrush.
- (7) A small screwdriver.

e. To clean the weapon (Instructor Discussion)

f. Checklist

Use the following checklist as a step-by-step procedure for cleaning the firearm. Instructors should demonstrate these steps by cleaning their own firearm. Each student should practice cleaning his or her firearm.

- (a) Make sure the firearm is unloaded.
- (b) Point barrel downward so that debris does not enter the action.
- (c) Make sure all screws are tight as they loosen periodically.
- (d) Use a bore brush and solvent to clean debris from barrel and action.
- (e) Put a bore patch in the patch holder.
- (f) Put solvent on the patch.
- (g) Push the patch through the barrel.
- (h) Wipe all surfaces with the patch.
- (i) Check around the barrel and inside top portion of revolver cylinder housing for residue build-up. If any is found, remove using toothbrush.
- (j) Push patch through the barrel (again).
- (k) Check barrel for lead deposits. If any are found, remove using bore brush.
- (l) Clean all solvent off with a clean bore patch.
- (m) Put oil on a patch and insert patch in holder.
- (n) Repeat steps (g) and (h) with the oily patch.

#### **IV. WEAPON HANDLING AND SHOOTING FUNDAMENTALS**

##### **A. Weapon Fundamentals, general differences between handguns.**

Differences between handguns

1. Revolvers: Have a revolving cylinder containing cartridges.

2. Semi-automatics: Use the force of the explosion of the cartridge to eject and reload cartridges. Cartridges are contained in a magazine loaded into the magazine well.

## **B. Loading and Unloading**

### 1. Proper Loading Procedures

There are proper methods of loading and unloading a firearm. If firearms are not allowed in the classroom, the instructor at the range may demonstrate this portion of instruction.

### 2. Proper Loading Procedures (right-handed)

#### **a. Revolver**

1. Grasp the revolver grip in the right hand.
2. Place the revolver so that the front of the trigger guard (where it joins with the bottom of the frame) is resting in the webbing between the thumb and index finger of the left hand.
3. Release the cylinder with your right hand. This is accomplished by either pushing or pulling the cylinder release depending on the type of revolver used.
4. Push the cylinder to the left of the gun using the second finger and ring finger of the left hand. At this point, the cylinder should be cradled with the thumb on one side and the second and ring fingers of the left hand on the other.
5. Pointing barrel down, (in a safe direction) insert the empty cartridges (inert training rounds in the classroom, live ammunition on the range or on duty) with the right hand. Turn the cylinder as needed with the thumb of the left hand.
6. Speed loaders and other loading devices must be compatible with weapon and grip. (Demonstration and discussion).
7. To close the cylinder, put the cylinder release in the open position. Gently but firmly close the cylinder. Let go of the cylinder release. Turn the cylinder until it locks in place. Do not slam or snap the cylinder. If you do, you may bend the tip of the extractor and the cylinder will not open again.

#### **b. Semi-Automatic**

1. Loading the Magazine
  - (a) Insure cartridges are correctly aligned



- (b) Know the capacity of the magazine.
- 2. Placing Magazine into the Firearm (Slide locked open)
  - (a) Grasp firearm with strong hand, pointing it in a safe direction.
  - (b) With the magazine in weak hand, place index finger along leading edge of the magazine pointing toward the top of the magazine.
  - (c) Rotate strong wrist outward until the magazine well is visible.
  - (d) Insert magazine smoothly and firmly into the magazine well until it locks. Do not "slam" magazine into the firearm.
  - (e) Keep finger away from trigger, release slide. Do not ease slide forward. Allow recoil spring to freely move the slide.
  - (f) Activate safety or decocking lever.
- 3. Proper Unloading Procedures (right-handed)

**a. Revolver**

To unload the revolver, the procedure is almost identical to the loading procedure.

1. Place the revolver in the left hand as in the loading procedure.
2. Open the cylinder as in the loading procedure.
3. Place your second and ring fingers of the left hand through the cylinder housing in the frame.
4. Point the barrel up.
5. With the ejector rod, push the empty casings forcefully out of the cylinder. It may be necessary to pull some of the casings out with your right hand if they do not fall out.
6. Allow brass to fall freely. (Discussion).

**b. Semi-Automatic**

1. Point firearm in a safe direction, keeping finger away from trigger.

2. Remove magazine.
3. Keeping muzzle in safe direction, rotate wrist until the slide is lower than the frame.
4. Pull the slide to rear to eject any chambered round.
5. Lock slide to rear.
6. Inspect by sight and feel to verify empty chamber.

4. Proper Loading Procedure (Left Handed)

a. **Revolver**

1. Grasp the grip of the revolver with the left hand and cradle in the right hand.
2. Release cylinder by pushing cylinder release.
3. With the thumb of the right hand, push the cylinder open, leaving the thumb extended through the cylinder housing.
4. Cradle the cylinder with the right thumb and the third and fourth fingers of the right hand.
5. Insert bullets into cylinder with the left hand.
6. Close the cylinder with the second and ring fingers of the right hand.

5. Proper Unloading Procedures (Left Handed)

a. **Revolver**

1. Follow steps (1) through (4) above.
2. Place the right index finger on the ejector rod and forcefully push the empty casings out of the cylinder.
3. Allow the brass to fall freely.
4. Use the left hand to pull out empty casing, if necessary.

6. Loading Devices. (Instructor Discussion)

**C. Proper Positions**

Explain and demonstrate to students in the Course of Fire that two shooting stances, standing and kneeling, will be used on the range. However, five proper positions will be demonstrated and taught: (1) Point Shoulder position. (2) Standing, barricade or supported position. (3) Kneeling position. (4) Sitting position. (5) Prone position. The instructor should also discuss (6) Cover and Concealment and (7) Bouncing bullets.

1. Point Shoulder Position (Demonstration and Practice).

- a. Stand directly in front of the target.
- b. Spread your feet approximately shoulder's width apart but not to the point where you are uncomfortable. Stand squarely facing the target.
- c. Put your weight on the balls of your feet. This will allow you to turn your position a full 90 degrees to either side, should the need arise. Keep your back straight.
- d. Flex your knees. The degree of flexibility varies with individuals. This position promotes several advantages:
  - (1) Aids in weapon retention.
  - (2) Lowers your center of gravity.
  - (3) Makes you a smaller target.
  - (4) Helps to keep you steady.
  - (5) Helps absorb recoil.
  - (6) Aids in rapid recovery.
  - (7) Provides a natural point.

2. Standing, barricade or supported position (Demonstration and Practice)

- a. Stand with both feet behind a barricade.
- b. Remove the firearm from the holster with the strong hand.
- c. Bring the firearm up to eye level, extending the hand beyond the barricade or supported by the other hand that is against the barricade.
- d. The barricade should shield the body at all times.

Position

- (1) Right-handed position on barricade.
- (2) Left-handed position on barricade.

3. Kneeling Position (Demonstration and Practice).

- a. Kneeling on one knee, the other knee is extended toward the target.
  - b. One arm may be supported on the forward knee.
  - c. The firearm may be held by one or both hands.
4. Sitting Position (Demonstration and Practice).
  5. Prone Position (Demonstration and Practice).
  6. Cover and Concealment (Instructor discussion)
    - a. Know the type of material you are using for cover (such as barricades made of wood or metal).
    - b. Locate your next position.
    - c. Do not leave cover if you do not have to.
    - d. Do not confuse concealment with cover (define).
      - (1) Concealment -- being hidden from view.
      - (2) Cover -- protection from fire.
  7. Bouncing/Ricocheting Bullets (Instructor discussion)

In shooting, the path a bullet travels can not be controlled. Bullets will bounce and ricochet after striking an object, including a person. Bouncing bullets can result in the injury or death of an innocent person, even one who is far away. The potential for injury from a bouncing bullet requires you to be aware of this possibility in a shooting.

In addition to shooting only if you are justified, you may want to order people to fall on the floor or take cover before shooting.

#### **D. Grip:**

The proper grip is very important. If the firearm is not gripped properly, the shot will not be accurate. The firearm cannot be gripped correctly unless it fits the shooter's hand. The proper shooting handgrip places the firearm in the webbing between the thumb and index finger of the shooting hand. The index finger should lie with the trigger resting on the bulb of the index finger. This course includes two basic grips, the one-handed grip and two-handed grip.

1. Two-Handed Grip (Demonstration and Practice).

2. One-Handed Grip (Demonstration and Practice).

## **E. The Draw**

The instructor may demonstrate the technique in the classroom or at the firing range.

1. General Information. (Instructor Discussion)

- a. Safety first.
- b. Keep finger out of trigger guard until the firearm has cleared the body.
- c. Maintain control of firearm and point the muzzle down range.

2. The Holster and The Draw

- a. Hands should be kept off of the holstered firearm except when drawing or shooting. Do not use the grip of a holstered pistol as a resting-place for a hand, forearm or elbow.
- b. A wide variety of holsters are available with different safety features. Use of any holster should be demonstrated and discussed as appropriate. When drawing the firearm from the holster the following technique may be used. This technique will change depending on the type of holster used. (Right-handed example given).
  - (1) RELAX. Do not look at holstered firearm. Eyes should remain on the target.
  - (2) Set right hand down on rear strap of the firearm and establish a firm grip. Keep the "trigger finger" out of the trigger guard.
  - (3) When the muzzle has cleared the holster, raise the firearm to a horizontal position.

Instructors should **explain** and **demonstrate** the draw often to ensure that students understand the techniques. Also, answer all questions and continue to stress firearm safety.

**STRESS SAFETY, CONTROL and SMOOTHNESS, NOT SPEED.**

Students will, on command, draw and go through a sequence of dry fire as instructed. Students will stay on target to assess threat. Students will holster on command. (This must be a conditioned reflex.)

Repeat the draw, point, dry fire and subsequent safety aspects of this exercise. Instructors will correct draw and safety procedures.

Objectives of Exercise

To teach and reinforce the safe draw, to condition safety procedures and to familiarize the student with firearm handling so they become safe, efficient and comfortable. The exercise allows the student an opportunity to become accustomed to the idea and feel of protective equipment. (See Illustration "D" on page 80)

ILLUSTRATION "D"

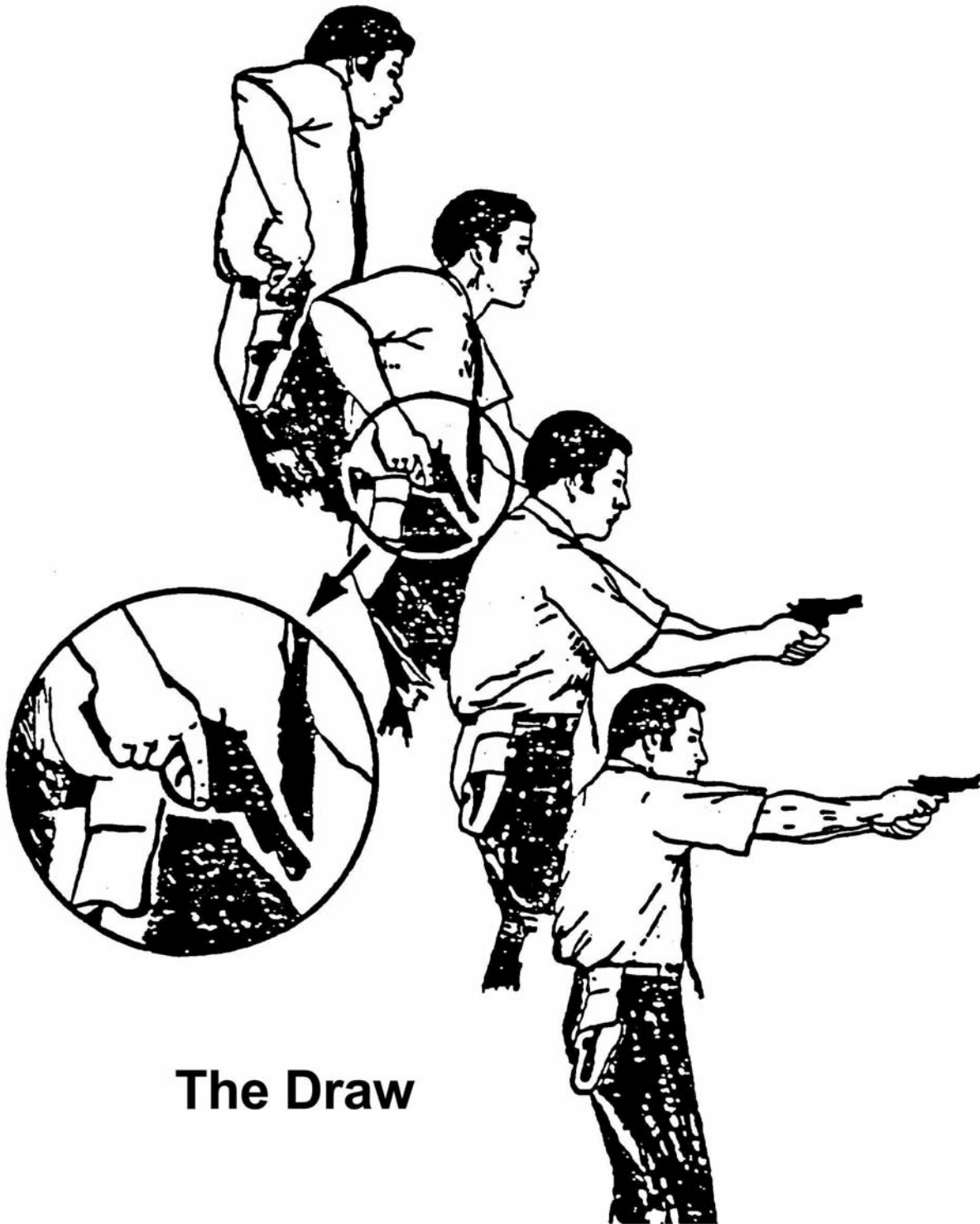

## The Draw

### F. Shooting Fundamentals

## 1. Sight Alignment

Aiming is a combination of lining up the front and rear sights with the target. "Sight Picture" or aiming, is the basis of good shooting. When discussing the principles involved it is necessary to understand the principle of "Sight Alignment."

The term "sight alignment" refers to what is seen through the sights of the firearm without consideration of the target. This is proper sight alignment. The front sight is in the exact center of the uprights of the rear sight. The top of the front sight is also even with the top of the upright portion of the back sight. (See Illustration "E" on page 84).

The term "sight picture" refers to that which is seen through the sights of the firearm, including the target. *The position of the front sight is in the center of the upright portion of the rear sight and is even with the top of the rear sight.*

*The position of the front sight indicates where the bullet will travel.* If the front sight is in the middle of the rear sight but is lower than the uprights, the shot will be low. The reverse is true also where the horizontal alignment is correct but the front sight is high, the shot will be high. Also, if the vertical alignment is correct but the front sight is to one side, the shot will be to that side.

The sights and target can never be in focus at the same time. The sights should be in focus and the target should be blurred.

The firearm should be held in a manner that allows the sight picture to be seen straight up and down. If the sight picture is tilted, it is called "canting." Canting will also cause the bullet to land to the side of the target.

## 2. Trigger Squeeze (control)

Despite correct stance, grip, and sight picture, the shot will be inaccurate if the trigger is snapped instead of squeezed. The term "trigger squeeze" means the smooth and steady pressing of the trigger. If the trigger is snapped, the barrel will jump in the hand. This will cause the shot to miss.

The firearm should be gripped so that the first joint from the tip of the index finger lies on top of the trigger. This produces a straight pull.

Placing too much of the finger on the trigger, will cause the firearm to shift to the outside of the target. If too little finger is put on the trigger, the firearm is pushed to the inside by the squeeze. (Demonstration)

- a. Single action shooting



Single action shooting is using the trigger to fire an already cocked weapon. Single action shooting with a revolver is not acceptable.

b. Double action shooting

Double action shooting is using the trigger to cock and fire the weapon.

c. Count your shots

Students should always be aware of the amount of ammunition they have.

d. Anticipation

The most common mistake made by the novice shooter is anticipating the shot. Anticipation will generally result in one of three patterns.

- 1) If the shooting pattern begins to trail upward, the shooter is withdrawing from the recoil.
- 2) If the shooting pattern begins to trail downward, the shooter is anticipating the firearm's recoil and is pushing the muzzle downward.
- 3) If the shooting pattern is either to the left or right, the shooter does not have proper body position, does not have proper sight alignment, or proper trigger finger placement.

Anticipation can be diagnosed by placing two or three live rounds randomly in the cylinder and filling the remaining chambers with empty casings. This is called "skiploding." Spin the cylinder and close the cylinder without looking at the cartridges. Squeeze six shots. If the barrel drops or rises on either squeeze, the shooter is anticipating the shot.

Snapping the trigger will cause the barrel to jump resulting in an erratic shooting pattern. Although the barrel may jump a fraction of an inch, the angling has caused the bullet to be off several inches by the time it reaches the target.

e. Dry Firing

Erratic shooting patterns may be corrected once the shooter learns to concentrate on the "sight picture" and not the recoil. The student should be allowed to practice shooting the firearm without ammunition. This is called, "dry firing."

3. Establishing the Dominant Eye. (Instructor Discussion)

An important step in proper sight alignment is establishing the "dominant eye." This is the eye that must be opened when aiming the firearm. To determine which eye is dominant, students should do the following:

- a. Hold out their hand in front of them and make a circle with the thumb and forefinger.
- b. Look through the circle at an object some distance away, using both eyes.
- c. First close one eye and then the other. Whichever eye is open when the object stays in the circle is the dominant eye.

#### 4. Breath Control

Breathing is important in good shooting. When breathing normally, the shooter's chest movement will cause changes in the sight alignment and sight picture. Proper breath control does not cause the weapon to move.

Several deep breaths before firing will draw extra oxygen into the lungs. The shooter can then refrain from breathing for the few seconds that it takes to get the firearm into alignment and fire it. Holding the breath too long will cause the body to tremble. It will also cause the sights to become fuzzy since the eyes may begin to water.

Taking a final deep breath and exhaling will help complete a string of fire without additional breathing.

ILLUSTRATION "E"

## Correct Sight Alignment

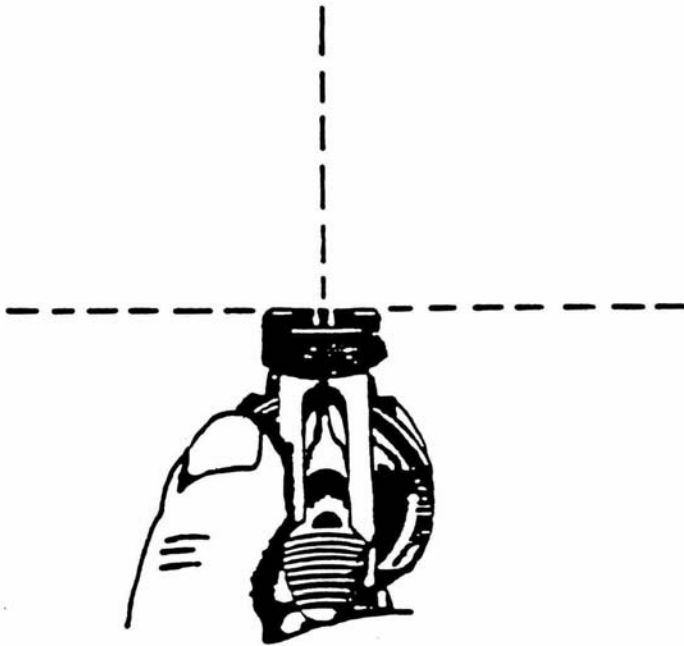

Revolver

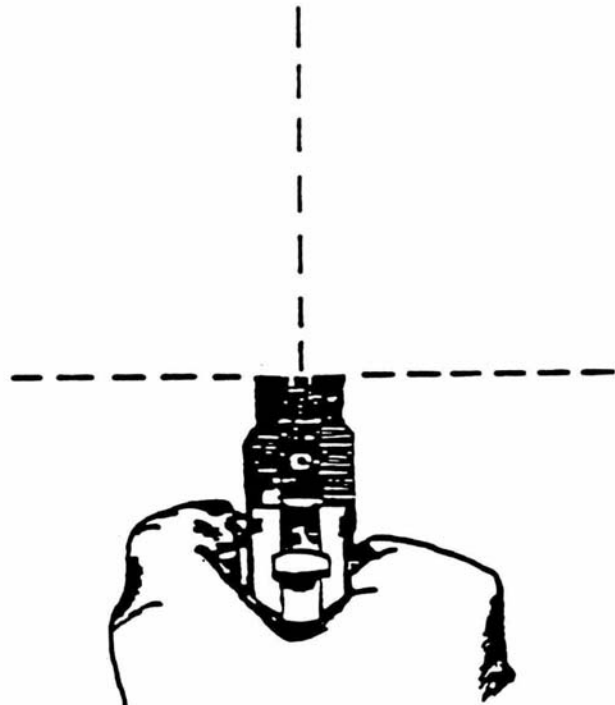

Semi-automatic

### V. EXAMINATION

Upon completion of classroom instruction for the Initial Firearm Training, the instructor is to administer the written examination. The student must pass the written examination by a score of 85 percent or greater.

Applicants with a current firearm permit who are completing any of the first three semi annual range qualifications are required to complete the two hour refresher course, but are not required to take the written exam.

Applicants with a current firearm permit who are completing their fourth Semi-annual range qualification for the purpose of renewing a firearm permit must complete a two hour refresher course and pass the written examination.

- A score of 44 out of possible 51 questions, or 85 percent, is required to pass the written examination (the questions regarding the nomenclature count as one question each).

**NOTE: If a student fails to pass the written examination, he or she must repeat the entire classroom instruction before retaking the written examination. (Business and Professions Code Section 7585.6(c))**

## **VI. RANGE PREPARATION**

Before allowing students onto the range, cover the following points:

### A. Range Location

If necessary, inform students of the directions to the shooting range. Also, explain proper procedure for transporting firearms to the range. (Refer to "Transporting the Weapon to the Range," **(Section III (D)(4).)**)

### B. Equipment needed

Explain what equipment will be provided by the training facility and what equipment the student must have.

### C. Course of Fire

Explain the course of fire in detail

Timing on the clock will begin at the instructor's command. Firing will begin from either the ready position or after the weapon is drawn from the holster.

### D. Targets, scoring explanation (NRA B-27A or NRA B-21)

Targets are to be scored as described in section VII RANGE TRAINING (6)a

### E. Range commands (explanation)

Review range commands. Remind students that the instructor and/or range master has the last word. Only they can decide who enters the firing range. If either the instructor or range master feels, for any reason, that a student presents a hazard, that student must leave the range upon their request.

#### F. Use of Deadly Force.

Familiarize and instruct the student on the meaning of deadly force, the standards for using deadly force, the applicable laws relating to the use of deadly force and the consequences of not properly using deadly force or violating the standards and requirements for use of a weapon.

### **VII. RANGE TRAINING**

This section should be covered at the range site immediately before actual firing.

#### A. Instruction

1. Registration: Students must possess the following before going onto the range:
  - a. A valid and current license/registration or proof of application.
  - b. Photo and/or signature identification.
  - c. Proof of citizenship or permanent alien residence.
  - d. Evidence of successful completion of the classroom portion of the firearm training course as required.
  - e. A firearm and holster acceptable to the instructor or range master.  
Unacceptable weapons will not be allowed on the range.
2. Range Procedures and Discipline
3. Firearm Handling, Sights and Positions
  - a. Grip.
  - b. Loading.
  - c. Draw.
  - d. Sights.
  - e. Standing position.
  - f. Kneeling Positions.
  - g. Sitting Positions.
  - h. Single action shooting.
  - i. Double action shooting.
  - j. Dry firing.
  - k. Skip loading.
  - l. Targets: NRA B-27A, NRA B021 series or equivalent.

m. Firing distances: 15 yards, 7 yards, 5 yards and 3 yards.

4. Course of Fire

- a. Explain the qualification course of fire.
- b. Explain the sequence of firing.
- c. Explain and discuss the two positions will be used: (1) Standing and (2) kneeling.

Allow students to practice these positions to determine which is most suited to their individual abilities.

5. Qualification Course Conditions

- a. All double action shooting with revolver.
- b. One and two-handed shooting may be used. However, two-handed shooting is recommended.

6. Target Scoring

- a. The body-kill area is defined as any area within the five- (5) point “bottle” area of the NRA B-27A or NRA B-21 series. Note: All other areas are a miss.
- b. All shots count, even if the firearm accidentally discharges.
- c. A shot hole, the leading edge of which comes in contact with the outside of the scoring area, will be scored as 5 points.

7. Late Shots

- a. When a shot is fired after the allotted time, it will be scored as a zero (“0”).

Late shots may be authorized by the range master or instructor if, in their judgement, a malfunction of the firearm was responsible.

- b. The range master or instructor will be advised of unfired ammunition.

(NOTE: If a student fails to qualify, range instruction may continue. However, to receive a firearm permit, the student must successfully qualify within 30 days of passing the classroom instruction. (Business and Professions Code Section 7585.6(b))

B. Drawing and Holstering Practice (Range or Classroom)

Using an empty firearm, students will, on command, grasp the firearm and draw in a safe prescribed manner. Then, on command, the students will reholster the firearm. Repeat this exercise several times until students: (1) are handling the firearm safely;

(2) know the safety observations noted by the instructor; and (3) are not putting the trigger finger inside the trigger guard until the firearm is pointed safely down range.

### C. Dry Firing (Range or Classroom)

Using an empty firearm students will, on command, fire several times to become accustomed the pull of the trigger.

### D. Loading and Reloading Procedures

1. Students should have the necessary number of cartridges to complete the course of fire (50 for actual range qualification and additional 50 rounds for range practice).

Students **must** qualify with the type (revolver or semi-automatic) and caliber weapon that they will carry on duty. Students may qualify with more than one weapon (type or caliber), however; the 50 round qualifying course must be shot with each additional weapon.

2. During training and qualification, students should load the firearm in the same manner they would while on duty and consistent with their equipment. For example, students carrying speed loaders on duty should load using the speed loaders during range training.
3. Students who do not possess duty equipment that properly holds extra ammunition must carry extra ammunition in a pocket or suitable container.

## **VIII. RANGE QUALIFICATION**

**Objective:** Individual shall pass the firearms qualification based on his or her demonstrated use of weapon.

- A. **A course of fire.** Each individual shall discharge 50 rounds a minimum of two times according to the following schedules:

(All stages are unsupported.)

Stage 1          15 yards          6 rounds in 30 seconds

- 6 standing position

Stage 2          7 yards          14 rounds in 45 seconds (includes 2 reloads)

(load 6, 6 and 2)

			<ul style="list-style-type: none"> <li>• 6 standing position</li> <li>• 8 kneeling position</li> </ul>
Stage 3	7 yards	6 rounds in 10 seconds (any position)	
Stage 4	7 yards	12 rounds in 25 seconds (includes reload)	
		(load 6 and 6)	
			<ul style="list-style-type: none"> <li>• 6 strong hand unsupported (reload and switch hands)</li> <li>• 6 weak hand unsupported</li> </ul>
Stage 5	5 yards	6 rounds	
			<ul style="list-style-type: none"> <li>• 3 rounds in 4 seconds (2 stages)</li> </ul>
Stage 6	3 yards	6 rounds	
			<ul style="list-style-type: none"> <li>• 2 rounds in 3 seconds (3 stages)</li> </ul>

**B. Scoring.** The first course of 50 rounds discharged shall be considered practice. The second course of 50 rounds discharged shall be used for scoring.

1. Silhouette targets shall be used. A 5 point score shall be granted for each round discharged in head or body kill area.
2. Each individual shall qualify with an 80% score (200 out of 250 points) on the scoring segment.
3. Each individual shall be informed whether his or her score passes or fails.

## IX. REQUALIFICATION

Firearm permits expire two years from the date of issuance. Thereafter, in order to possess a valid firearm permit, the permit must be renewed. Students wishing to renew a firearm permit must file an application for renewal at least 60 days before the date of expiration.



Firearm permits may be renewed under the following conditions:

- The licensee or registrant has filed a completed application for renewal, signed and dated under penalty of perjury, certifying that information on the application is true and correct.
- The licensee or registrant has successfully passed the written examination contained in the Firearm Training Manual issued by the Department of Consumer Affairs and taught at a bureau-certified facility. The passing score is 85 percent or 44 correct answers out of 51 questions.
- The licensee or registrant has completed all required range requalifications within the required time frames and has requalified on the range using the same firing sequence prescribed for the initial student, using the NRA B-27A or NRA B-21 series target, or equivalent. Targets will be scored at 5 points for a hit and 0 points for a miss.

Maximum Score	-	250 (50 rounds)
Passing Score	-	200 (80%)

- The licensee or registrant has submitted all required fees and proof of completing the required requalifications to the bureau.

## **X. EMERGENCY PROCEDURES**

In the event anyone is injured during or as a result of a shooting incident, you as a guard on duty, are expected to contact emergency medical personnel and local law enforcement immediately. What emergency medical assistance you provide to the injured person(s), if any, is dependent upon what directions and training you have received from your employer.

Since you may be carrying and using a firearm on the job, you are responsible to be prepared to act appropriately before, during and after a shooting. This includes being familiar with the emergency policies and procedures that your employer expects you to follow. If you have any questions, discuss the matter with your supervisor.

## **XI. PEACE OFFICER QUESTIONS AND ANSWERS**

### ***Frequently Asked Questions About Active Duty Peace Officers, Retired Peace Officers and Reserve Peace Officers***

The Bureau of Security and Investigative Services (BSIS) receives a wide variety of questions from and about peace officers. Below are some of the most commonly asked questions and answers. The questions are grouped by category, such as active duty peace officers and firearms.

Please keep in mind that different laws apply to different situations. For example, The Private Investigators Act covers private investigators (PI's), while the Private Security Services Act covers private patrol operators and security guards. Both these Acts are included in the Business and Professions Code (B&P Code).

This is further complicated by the fact that active duty peace officers, as defined in the Penal Code, have some limited exemptions in the B&P Code that civilians and retired peace officers do NOT have. For example, a security guard must possess a BSIS-issued baton permit and work in a security guard uniform to carry a baton while on duty. However, active duty peace officers are exempt from this requirement as explained in the Q&A below.

**ACTIVE DUTY PEACE OFFICERS EMPLOYED OFF-DUTY AS SECURITY GUARDS (BODYGUARD), OR PROVIDING CONTRACT SECURITY GUARD (BODYGUARD) OR CONTRACT PI SERVICES AND CARRYING A FIREARM OR A BATON**

**Q1:** Is an active duty peace officer working off-duty as a bodyguard in civilian clothes with a concealed firearm required to possess a BSIS-issued exposed firearm permit and guard card?

**A:** Yes. An active duty peace officer must possess a BSIS-issued exposed firearm permit and guard card to work in civilian clothes as a bodyguard in an armed capacity.

**Q2:** What BSIS license and permit must an active duty peace officer possess to contract to provide armed bodyguard services for VIPs or celebrities?

**A:** A BSIS-issued Private Patrol Operators (PPO) license and an exposed firearm permit is required. Only a licensed PPO may contract to provide bodyguard services or security guard services to any person or entity.

**Q3:** Why are California peace officers required to: (a) possess a BSIS-issued exposed firearm permit and guard registration to be employed as an armed security guard (or bodyguard); or (b) possess a BSIS-issued exposed firearm permit and a PI license to provide armed PI services on contract?

**A:** Since January 1, 1997, the law has required active duty peace officers who work armed as security guards, alarm company employees, or contract PI's, to possess a valid registration/license AND an exposed firearm permit issued by BSIS.

**Q4:** May an active duty peace officer with a BSIS guard card an exposed firearm permit contract with a VIP or celebrity to provide bodyguard services in civilian clothes while carrying a firearm?

**A:** No. Only a BSIS licensed private patrol operator (PPO) may contract to perform security guard or bodyguard services to any person or business. An active duty peace officer with a guard card and an exposed firearm permit issued by BSIS may perform armed security guard (bodyguard) duties only as a security guard employee. The employment relationship must be

with either a PPO, who has the contract to perform the service, or with the person or business for whom the security service is being performed.

**Q5:** Is an active duty peace officer required to submit fingerprints for a criminal record review as an applicant for a BSIS-issued guard card, firearm permit, Private Patrol Operator license, or a PI license, since as a peace officer, his/her prints are already on file with DOJ?

**A:** Yes. The B&P Code requires that applicants undergo a BSIS criminal record review. If an applicant does not submit fingerprints to DOJ, BSIS is not authorized to receive the criminal record from DOJ.

**Q6:** When may an active duty peace officer begin working as an armed guard (or bodyguard) once a completed guard and exposed firearm application is submitted, including proof of peace officer status, fingerprints and payment of all fees?

**A:** Immediately. Because active duty peace officers have undergone a thorough background check, including a criminal record review, and have extensive firearm training, they may begin working immediately once they submit a completed application to BSIS. However, should the criminal record review reveal a criminal or court record that prohibits the applicant from working as an armed guard, the applicant may NOT work as an armed guard, even if the applicant is an active duty peace officer.

**Q7:** Is an active duty peace officer required to submit fingerprints for a criminal record review as an applicant for a BSIS-issued guard card, firearm permit, alarm company employee registration, Private Patrol Operator license, or a PI license, since as a peace officer, his/her prints are already on file with DOJ?

**A:** Yes. The B&P Code requires that applicants undergo a BSIS criminal record review. If an applicant does not submit fingerprints to DOJ, BSIS is not authorized to receive the criminal record from DOJ.

**Q8:** Is an active duty peace officer required to complete and pass the BSIS firearm course in order to receive a BSIS exposed firearm permit?

**A:** No. However, the applicant must submit proof of peace officer status.

**Q9:** Is an active duty peace officer required to possess a BSIS-issued baton permit to carry a baton on duty as a guard (bodyguard)?

**A:** No. The B&P Code exempts active duty peace officers from possessing a BSIS baton permit when working off-duty as a guard (bodyguard).

**Q10:** Is an active duty peace officer who possesses a BSIS-issued exposed firearm permit required to satisfy the BSIS firearm range re-qualifications in order to renew the firearm permit?

**A:** No. Active duty peace officers who are authorized and qualified by their employer (law

enforcement agency) to carry a firearm are exempt from the BSIS firearm re-qualifications.

**Q11:** May an active duty peace officer contract to provide armed bodyguard services?

**A:** No. Only a person with a BSIS-issued private patrol operator's license (PPO) may contract to provide security services. A PPO license is required to provide security guard (bodyguard) services on contract to any person or business.

A security guard may not act as an independent contractor to provide security services. A security guard must be employed as an employee of either a PPO, or the person, or business for whom the guard is providing security services.

**Q12:** May an active duty peace officer contract with a licensed PI to perform PI duties?

**A:** No. Only a Licensed PI may contract to perform PI duties.

**Q13:** May an active duty peace officer with a PI license contract to provide a bodyguard service?

**A:** No. A bodyguard is a security guard. Therefore, only a PPO may contract to specifically provide a bodyguard service. However, a PI who has a contract with a client, may provide a bodyguard service to the client if that service is peripheral to an on-going PI contract.

An active duty peace officer must possess a guard card and an exposed firearm permit to be employed as a bodyguard and work in civilian clothes with a concealed weapon.

### **FEDERAL AND OUT-OF-STATE LAW ENFORCEMENT OFFICERS:**

**Q14:** Do the exemptions discussed in questions 8, 9 and 10 above apply to active duty federal law enforcement officers, including Federal Protective Service Officers (FPOs)?

**A:** Yes, if officers submit proof of federal law enforcement officer or FPO status and federal firearm qualifications to BSIS.

**Q15:** Do the exceptions in questions 8, 9, and 10 above apply to active duty law enforcement officers from other states?

**A:** No. Out-of-state law enforcement officers must comply with all BSIS requirements.

**Q16:** May an active duty federal law enforcement officer, including FPOs, perform PI duties and carry a firearm while working as an employee of a licensed PI?

**A:** Yes. Active duty federal law enforcement officers and FPOs may perform PI duties while armed, without a BSIS-issued firearm, while employed by a licensed PI.

**Q17:** Are active duty federal law enforcement officers and FPOs required to possess a BSIS-issued baton permit when working as security guards?

**A:** No. Active duty federal law enforcement officers are exempt from possessing the BSIS-issued

baton permit.

### **RESERVE PEACE OFFICERS**

**Q18:** Are reserve peace officers required to complete the initial BSIS course of fire?

**A:** No. Reserve peace officers who are authorized and qualified by their employer (law enforcement agency) to carry a firearm are exempt from the BSIS firearm qualifications.

**Q19:** Are reserve peace officers required to complete the BSIS quarterly firearm range re-qualifications?

**A:** Yes and no. No, if the reserve peace officer submits proof of firearm training and qualifications from the law enforcement agency with whom he/she serves. Yes, if the reserve officer does not submit such proof.

**Q20:** Are reserve peace officers required to possess a BSIS-issued baton permit while employed as a security guard or bodyguard?

**A:** No. The B&P Code exempts reserve peace officers from possessing a BSIS baton permit when working off-duty as a guard (bodyguard).

### **RETIRED PEACE OFFICERS**

**Q21:** Are honorably retired peace officers with an endorsement to carry a concealed weapon, required to possess a BSIS-issued guard card and firearm permit and baton permit to work as uniformed security guards with an exposed weapon or as bodyguards in civilian clothes with a concealed weapon?

**A:** Yes. Retired peace officers with an endorsement to carry a concealed weapon must complete all required training and possess a BSIS-issued guard card, firearm permit and baton permit in order to work as a uniformed security guard with an exposed firearm and baton or as a bodyguard in civilian clothes with a concealed weapon. A retired peace officer may not carry a concealed baton.

**Q22:** May an honorably retired peace officer with an endorsement to carry a concealed weapon, perform PI duties and carry a concealed firearm while working as an employee of a licensed PI?

**A:** Yes. An honorably retired peace officer with an endorsement to carry a concealed weapon may work armed without a BSIS-issued firearm permit while performing PI duties when employed by a licensed PI.

**Q23:** May an honorably retired peace officer with an endorsement to carry a concealed firearm, and with a BSIS-issued guard card, firearm permit and baton permit carry a concealed baton while on duty in civilian clothes as a security guard or body guard?

**A:** No. Retired peace officers must be in a security guard uniform to carry a baton. A retired peace officer with an endorsement to carry a concealed weapon, and with a BSIS-issued firearm permit and guard card may carry a concealed firearm but not a concealed baton while working in civilian clothes as a bodyguard or security guard.

### **SECURITY GUARDS AND BODYGUARDS:**

Under the B&P Code, security guards and bodyguards are the same and are covered by the same laws. A bodyguard is a security guard. Peace officers frequently tell BSIS staff that since they are working in civilian clothes with a concealed weapon as bodyguards for VIPs or celebrities, they are not security guards. This is incorrect. However, if the peace officer is on the payroll of the VIP with legal deductions for taxes being withheld via a W-2 they are not required to have a PPO.

The laws, rules and regulations that apply to security guards apply to bodyguards. For example: If a security guard must be in a security guard uniform to carry an exposed weapon, then a bodyguard must be in a uniform to carry an exposed weapon. If a security guard who works in civilian clothes with a concealed weapon must possess a guard card and exposed firearm permit, and either possess a Concealed Firearms Permit (CCW), or be an honorably retired peace officer with an endorsement to carry a concealed weapon, or be an active duty peace officer, then a bodyguard who works in civilian clothes with a concealed weapon must possess a guard card, an exposed firearm permit and either possess a CCW, or be an honorably retired peace officer with an endorsement to carry a concealed weapon, or be an active duty peace officer.

### **EXPOSED FIREARM PERMIT AND CONCEALED FIREARM PERMIT (CCWS):**

The B&P Code authorizes BSIS to issue Exposed ONLY Firearm Permits. The Penal Code authorizes local law enforcement agencies to issue CCWs. BSIS is not authorized to issue CCWs. Most active duty peace officers, and many reserve peace officers, are authorized to carry a concealed weapon off-duty. Honorably retired peace officers often possess an endorsement from a former employer to carry a concealed weapon.

### **IMPORTANT NOTICE:**

Active duty peace officers should exercise caution when identifying themselves as peace officers while working off-duty as bodyguards or security officers. This is a very complex issue involving the interplay of Penal Code Section 70, case law and the B&P Code.

The general rule that a peace officer is a peace officer 24 hours a day on or off-duty may NOT apply when a peace officer is working off-duty out of uniform. You are advised to seek legal advice and follow the directions of your local law enforcement agency. You are also advised to familiarize yourself with *Melendez v City of Los Angeles* (1998) 63 Cal. App. 4th 1; 73 Cal. Rptr. 2d 469.

### **CONTRACT AND EMPLOYEE:**

The B&P Code specifies who may engage in an enforceable contract to provide a service and who

must work as an "employee."

Generally, a contractor is not on payroll, is paid without deductions, and receives an IRS form 1099 for tax purposes. A contractor has a contract to provide a service.

An "employee" is a person who has an employer-employee relationship with the employer. Generally, this means that the person is on a payroll, and all appropriate payroll deductions are taken, including federal and state taxes, and the employee receives an IRS W-2 for tax purposes. If you are unclear about the differences and how you may be affected, please seek legal advice or discuss the matter with your agency.